

X8

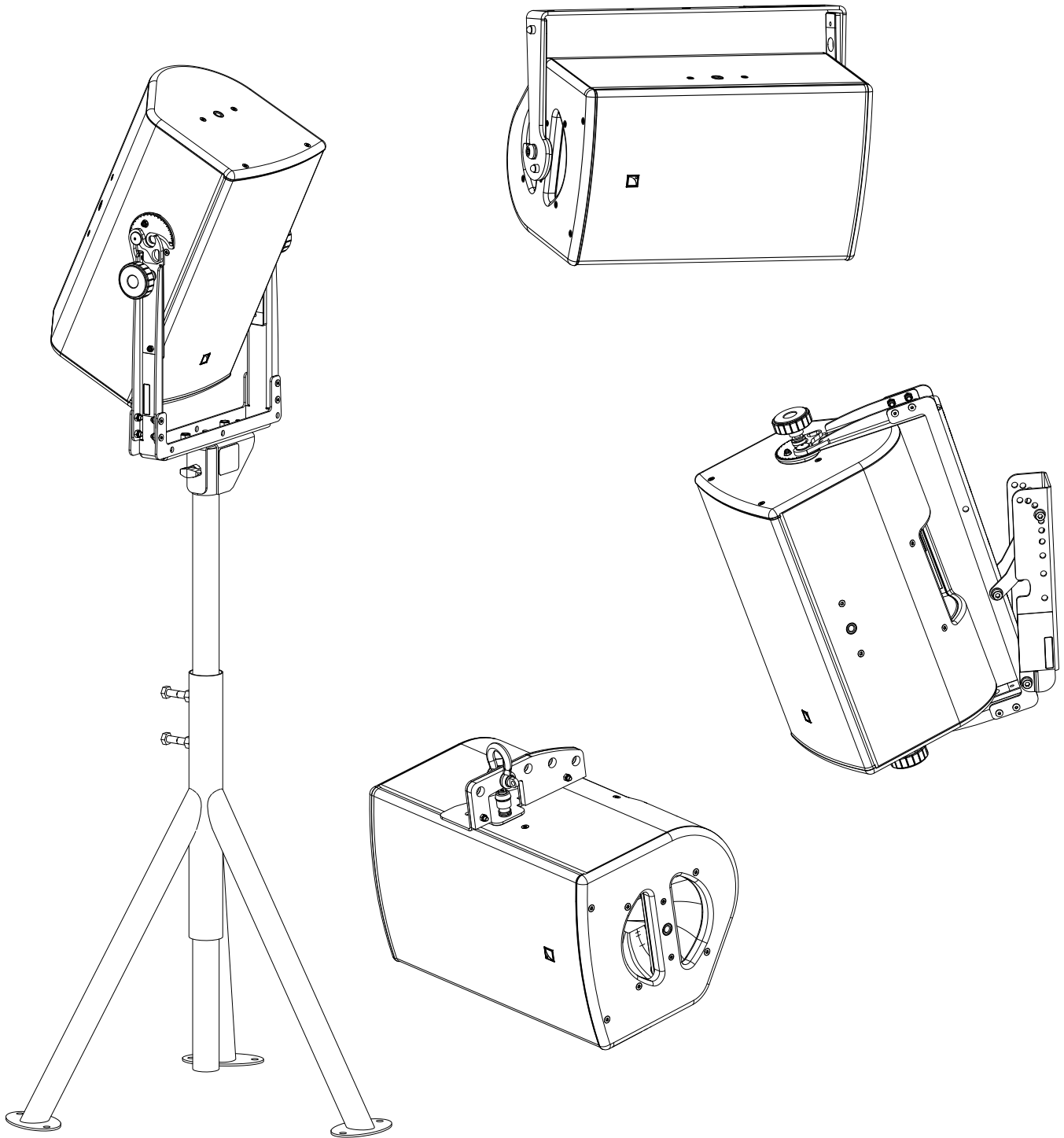

owner's manual (EN)



Document reference: X8 owner's manual (EN) version 2.0

Distribution date: October 29, 2024

© 2024 L-Acoustics. All rights reserved.

No part of this publication may be reproduced or transmitted in any form or by any means without the express written consent of the publisher.







Contents

Safety.....	5
Instructions.....	5
Introduction.....	7
X8 live monitoring enclosure.....	7
How to use this manual.....	7
Revision history.....	8
System components.....	8
Electro-acoustical description.....	11
Directivity.....	11
Preset description.....	12
Connectors.....	12
Rigging system description.....	13
X8.....	13
Elements for flying and wall-mounting.....	14
X-US8 and X-UL8.....	14
X-UL8i.....	17
X-UTILT.....	17
X-BAR.....	19
Elements for pole-mounting.....	20
Pole socket.....	20
EMBi.....	20
Subwoofer.....	21
Mechanical safety.....	22
Loudspeaker configurations.....	23
X8 point source.....	23
X8 point source with LF.....	24
X8 stage monitor.....	25
Low-latency preset.....	25
Paired X8 monitors with LFC.....	25
X8 stage monitor with LF.....	26
Inspection and preventive maintenance.....	27
How to do preventive maintenance.....	27
Rigging part inspection.....	27
Mechanical system overview.....	29

Inspection references.....	32
Acoustical check.....	33
Rigging procedures.....	37
Wall-mounting and ceiling-mounting.....	37
Mounting on X-US8 or X-UL8.....	37
Using X-US8 or X-UL8 with X-UTILT.....	41
Mounting on X-UL8i.....	47
Flying.....	50
Flying with X-US8 or X-UL8.....	50
Flying with X-UL8i.....	56
Flying with X-BAR.....	58
Pole-mounting.....	62
Pole-mounting with X-US8.....	62
Connection to LA amplified controllers.....	67
Corrective maintenance.....	69
Introduction.....	69
X8.....	70
Specifications.....	75
X8.....	75
SB15m.....	77
X-UL8.....	79
X-UL8i.....	80
X-US8.....	81
X-BAR.....	82
X-UTILT.....	83
EMBi.....	84
APPENDIX: Recommendation for speaker cables.....	85

Safety

Instructions

-  **Inspect the system before any deployment.**
Perform safety related checks and inspections before any deployment.
- Perform preventive maintenance at least once a year.**
Refer to the preventive maintenance section for a list of actions and their periodicity.
Insufficient upkeep of the product can void the warranty.
- If any safety issue is detected during inspection, do not use the product before performing corrective maintenance.**
Check for issues. A rigging system part or fastener is missing or loose. A rigging system part exhibits: bends, breaks, broken parts, corrosion, cracks, cracks in welded joints, deformation, denting, wear, holes. A safety cue or label is missing.
-  **Never incorporate equipment or accessories not approved by L-Acoustics.**
-  **Read all the related PRODUCT INFORMATION documents shipped with the products before exploiting the system.**
-  **Do not store the product on an unstable cart, stand, tripod, bracket, or table.**
-  **Beware of sound levels.**
Do not stay within close proximity of loudspeakers in operation.
Loudspeaker systems are capable of producing very high sound pressure levels (SPL) which can instantaneously lead to permanent hearing damage to performers, production crew, and audience members. Hearing damage can also occur at moderate level with prolonged exposure to sound.
Check the applicable laws and regulations relating to maximum sound levels and exposure times.
-  **Work with qualified personnel for rigging the system.**
Installation should only be carried out by qualified personnel that are familiar with the rigging techniques and safety recommendations outlined in this manual.
- Ensure personnel health and safety.**
During installation and set-up personnel must wear protective headgear and footwear at all times. Under no circumstances is personnel allowed to climb on a loudspeaker assembly.
- Respect the Working Load Limit (WLL) of third party equipment.**
L-Acoustics is not responsible for any rigging equipment and accessories provided by third party manufacturers. Verify that the Working Load Limit (WLL) of the suspension points, chain hoists and all additional hardware rigging accessories is respected.
- Respect the maximum configurations and the recommended safety precautions.**
For safety issue, respect the maximum configurations outlined in this manual. To check the conformity of any configuration in regards with the safety precautions recommended by L-Acoustics, model the system in Soundvision and refer to the warnings in Mechanical Data section.
- Be cautious when flying a loudspeaker configuration.**
Before installing/raising the product, check each individual element to make sure that it is securely fastened to the adjacent element. Always verify that no one is standing underneath the product when it is being installed/raised. Never leave the product unattended during the installation process.
As a general rule, L-Acoustics recommends the use of secondary safety at all times.
- Be cautious when ground-stacking a loudspeaker array.**
Do not stack the loudspeaker array on unstable ground or surface. If the array is stacked on a structure, platform, or stage, always check that the latter can support the total weight of the array.
As a general rule, L-Acoustics recommends the use of safety straps at all times.

Risk of falling objects

Verify that no unattached items remain on the product or assembly.

Risk of tipping

Remove all rigging accessories before transporting a product or an assembly.

Take into account the wind effects on dynamic load.

When a loudspeaker assembly is deployed in an open air environment, wind can produce dynamic stress to the rigging components and suspension points.

If the wind force exceeds 6 bft (Beaufort scale), lower down and/or secure the product or the assembly.



Intended use

This system is intended for use by trained personnel for professional applications.



As part of a continuous evolution of techniques and standards, L-Acoustics reserves the right to change the specifications of its products and the content of its documents without prior notice.

Check www.l-acoustics.com on a regular basis to download the latest document and software updates.



Long term exposure to extreme conditions may damage the product.

For more information, refer to the **Products weather protection** document, available on the website.



Read the maintenance section of this document before servicing the product.



Contact L-Acoustics for advanced maintenance.

Any unauthorized maintenance operation will void the product warranty.



This marking indicates that this product should not be disposed of with other household waste throughout the EU. To prevent possible harm to the environment or human health from uncontrolled waste disposal, recycle it responsibly to promote the sustainable reuse of material resources. To return your used device, please use the return and collection systems or contact the retailer where the product was purchased. They can take this product for environmentally safe recycling.



Introduction

X8 live monitoring enclosure

The X8 is a coaxial system designed for live monitoring and short throw sound reinforcement applications with minimum visual impact. The X8 features a 1.5" diaphragm compression driver coaxially loaded by an 8" low frequency transducer in a bass-reflex cabinet. The L-Vents laminar vented ports reduce turbulence and port noise at high levels to increase LF efficiency.

The X8 operates from 60 Hz to 20 kHz. The coaxial transducer arrangement and its partial horn produce a 100° axisymmetric directivity output with a smooth tonal response free of secondary lobes over the entire frequency range.

The internal passive crossover network uses custom filters. The L-Acoustics amplified controllers L-Drive parameters ensure the linearization and protection of the transducers.

How to use this manual

The X8 owner's manual is intended for all actors involved in the system design, implementation, preventive and corrective maintenance of the X8 system. It must be used as follows:

1. Read the technical description for an overview of all system elements, their features, and their compatibilities.
 - [Electro-acoustical description](#) (p.11)
 - [Rigging system description](#) (p.13)
2. Prepare the system configuration. Consider the mechanical limits and the available acoustical configurations.
 - [Mechanical safety](#) (p.22)
 - [Loudspeaker configurations](#) (p.23)
3. Before rigging the system, perform mandatory inspections and functional checks.
 - [Inspection and preventive maintenance](#) (p.27)
4. To deploy the system, follow the step-by-step rigging instructions and refer to the cabling schemes.
 - [Rigging procedures](#) (p.37)
 - [Connection to LA amplified controllers](#) (p.67)



The [Corrective maintenance](#) (p.69) section contains the operations authorized for the end user.

Performing another operation exposes to hazardous situations.

For advanced maintenance, contact your L-Acoustics representative.

As part of a continuous evolution of techniques and standards, L-Acoustics reserves the right to change the specifications of its products and the content of its document without prior notice. Please check www.l-acoustics.com on a regular basis to download the latest document and software updates.

Contact information

For information on advanced corrective maintenance:

- contact your Certified Provider or your L-Acoustics representative
- for Certified Providers, contact the L-Acoustics customer service: customer.service@l-acoustics.com (EMEA/APAC), laus.service@l-acoustics.com (Americas).

Symbols

The following symbols are used in this document:

 This symbol indicates a potential risk of harm to an individual or damage to the product. It can also notify the user about instructions that must be strictly followed to ensure safe installation or operation of the product.

 This symbol notifies the user about instructions that must be strictly followed to ensure proper installation or operation of the product.

 This symbol notifies the user about complementary information or optional instructions.

Revision history

version number	publication date	modification
1.0	Dec. 2021	<ul style="list-style-type: none"> • Migrated to owner's manual format. • Moved and clarified information from Forbidden configurations section to Rigging system description and Rigging procedures. • Added X-UL8i (p.17). • Updated Mechanical safety (p.22) according to EN 62368-1: 2014 standard. • Added pre-alignment delay values in X8 point source with LF (p.24) for subwoofers in cardioid configuration.
2.0	Oct. 2024	<ul style="list-style-type: none"> • Updated D/R - Grill (p.71). • Updated D/R - Coaxial loudspeaker (p.72). • Applied new branding guidelines (logo, font).

System components

Loudspeaker enclosures

X8 2-way passive coaxial enclosure: 8" LF + 1.5" HF diaphragm
 SB15m High power compact subwoofer : 1 × 15"

Powering and driving system

LA4X Amplified controller 4 × 1000 W / 8 ohms
 LA8 Amplified controller 4 × 1800 W / 4 ohms
 LA12X Amplified controller 4 × 2600 W / 4 ohms

 Refer to the LA4X / LA8 / LA12X owner's manual for operating instructions.

Racks

LA-RAK Touring rack containing three LA8 and power, audio and network distribution
 LA-RAK II AVB Touring rack containing three LA12X, LA-POWER II for power distribution, LA-PANEL II for audio and network distribution, and two LS10 for AVB distribution

Cables

SP cables SpeakON loudspeaker cables (4-point, 4 mm² gauge)

	Come in different sizes: SP.7 (0.7 m / 2.3 ft), SP5 (5 m / 16.4 ft), SP10 (10 m / 32.8 ft), and SP25 (25 m / 82 ft)
SP-Y1	Breakout cable for two passive enclosures (2.5 mm ² gauge) 4-point speakON to 2 × 2-point speakON, provided with a CC4FP adapter
DO cables	PA-COM loudspeaker cables (8-point, 4 mm ² gauge) Come in different sizes: DO.7 (0.7 m / 2.3 ft), DO.10 (10 m / 32.8 ft), and DO.25 (25 m / 82 ft)
DOSUB-LA8	Breakout cable for four passive enclosures (4 mm ² gauge) 8-point PA-COM to 4 × 2-point speakON

i Information about the connection of the enclosures to the LA amplified controllers is given in this document.

Refer to the LA4X / LA8 / LA12X owner's manual for detailed instructions about the whole cabling scheme, including modulation cables and network.

Rigging elements

X-UL8	Long U-bracket for X8
X-UL8i	Long U-bracket for X8 (installation version)
X-US8	Short U-bracket for X8
X-UTILT	U-bracket wallmount for X series with tilt adjustment
X-BAR	Rigging bar for 1 enclosure
EMBi	Pole mount socket: 8XTi/12XTi and X series
CLAMP250	Clamp certified for 250 kg

Software applications

Soundvision	3D acoustical and mechanical modeling software
LA Network Manager	Software for remote control and monitoring of amplified controllers

i Refer to the Soundvision help.
Refer to the LA Network Manager help.

System component illustrations

Cables

0.7 m / 5 m / 10 m / 25 m
2.3 ft / 16.4 ft / 32.8 ft / 82 ft

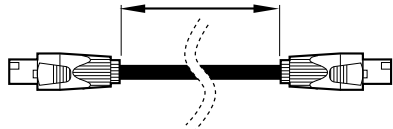

SP cables

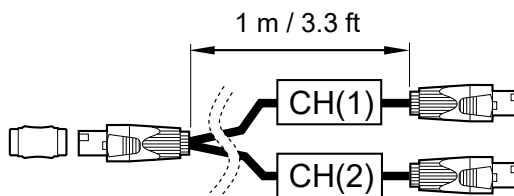

SP-Y1

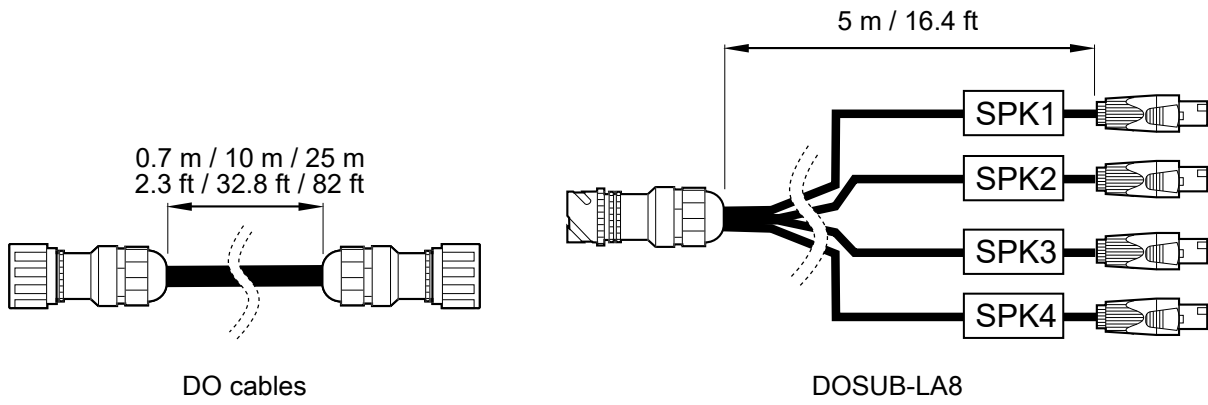

Rigging accessories

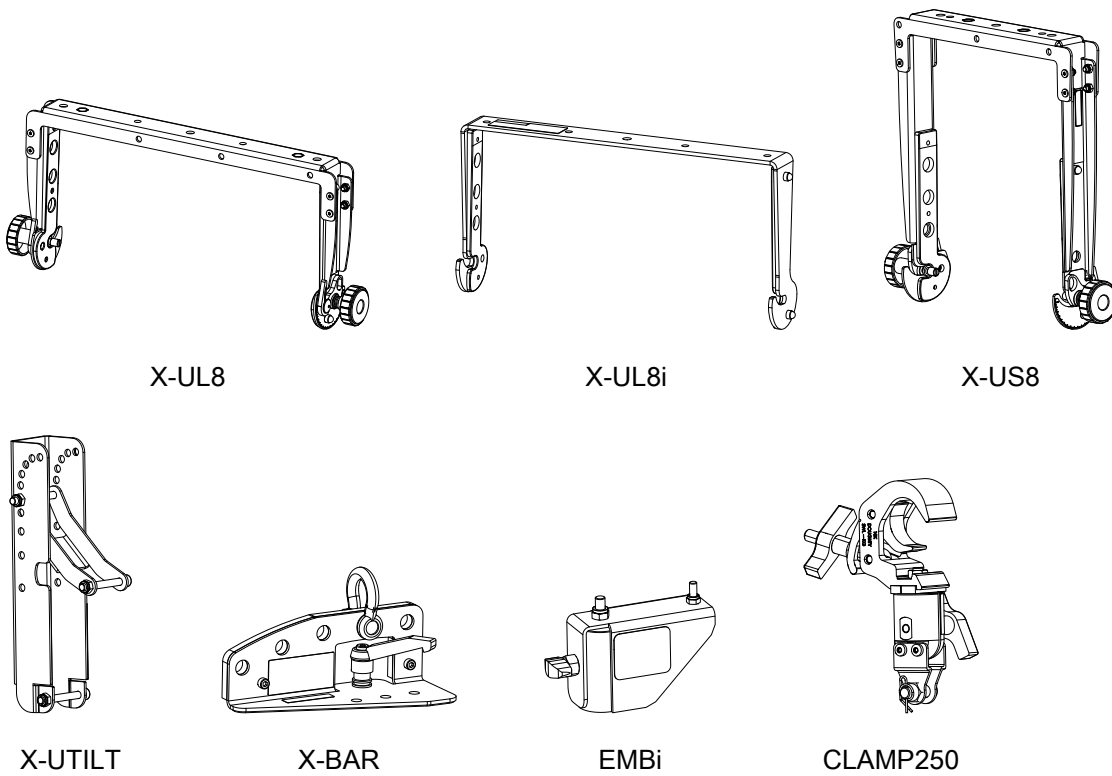

Software applications

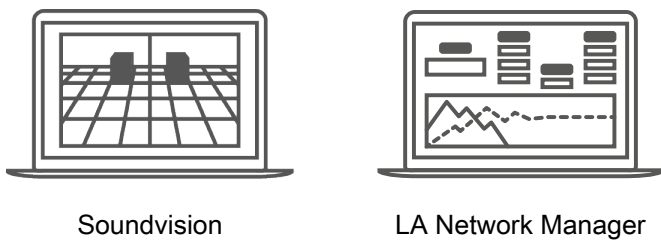

Electro-acoustical description

Directivity

X8 features a coaxial transducer arrangement that generates an axisymmetric directivity pattern of 100°.

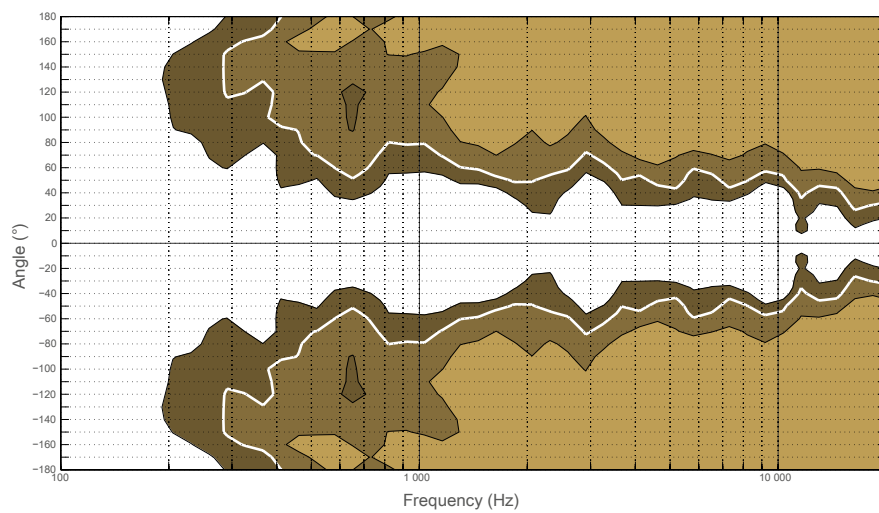
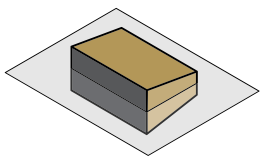
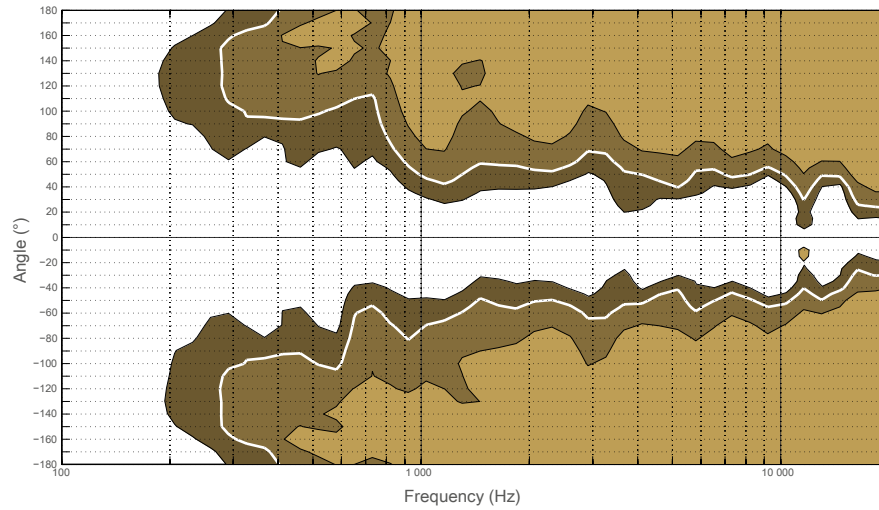
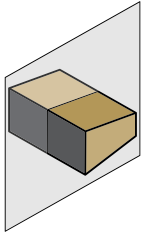

Dispersion angle diagram of a single X8 using lines of equal sound pressure at -3 dB, -6 dB, -12 dB.

Preset description

[X8] [X8_MO]

outputs	channels	routing	gain	delay	polarity	mute
OUT 1	PA	IN A	0 dB	0 ms	+	ON
OUT 2	PA	IN A	0 dB	0 ms	+	ON
OUT 3	PA	IN B	0 dB	0 ms	+	ON
OUT 4	PA	IN B	0 dB	0 ms	+	ON

[SB15_100]

outputs	channels	routing	gain	delay	polarity	mute
OUT 1	SB	IN A	0 dB	0 ms	+	ON
OUT 2	SB	IN A	0 dB	0 ms	+	ON
OUT 3	SB	IN A	0 dB	0 ms	+	ON
OUT 4	SB	IN A	0 dB	0 ms	+	ON

[SB15_100_C] [SB15_100_Cx]

loudspeaker elements	outputs	channels	routing	gain	delay	polarity	mute
SR	OUT 1	SR	IN A	0 dB	0 ms	+	ON
SB	OUT 2	SB					ON
SB	OUT 3	SB					ON
SB	OUT 4	SB					ON

Connectors



SpeakON connectors can be used interchangeably as IN or LINK connector.

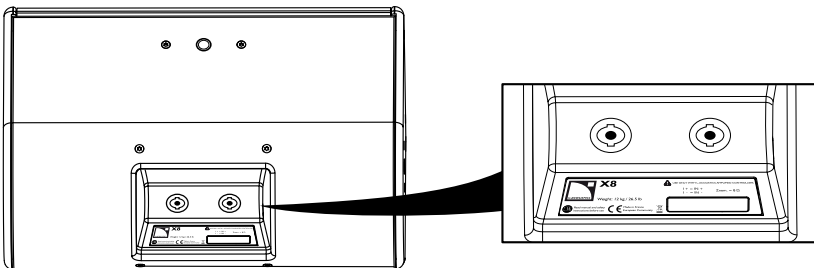

X8

2 × 4-point speakON

Internal pinout for L-Acoustics 2-way passive enclosures

SpeakON points	1 +	1 -	2 +	2 -
Transducer connectors	+	-	Not linked	Not linked

Rigging system description

X8

X8 features a M8 DIN580 threaded insert designed to implement a secondary safety.

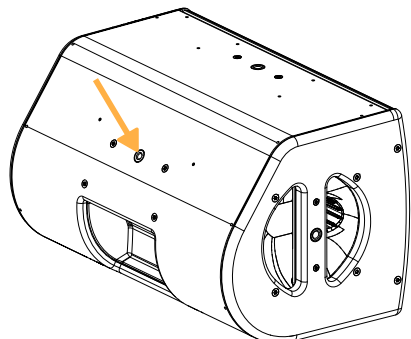

The logo on the enclosure front can be rotated to adapt to every configuration.

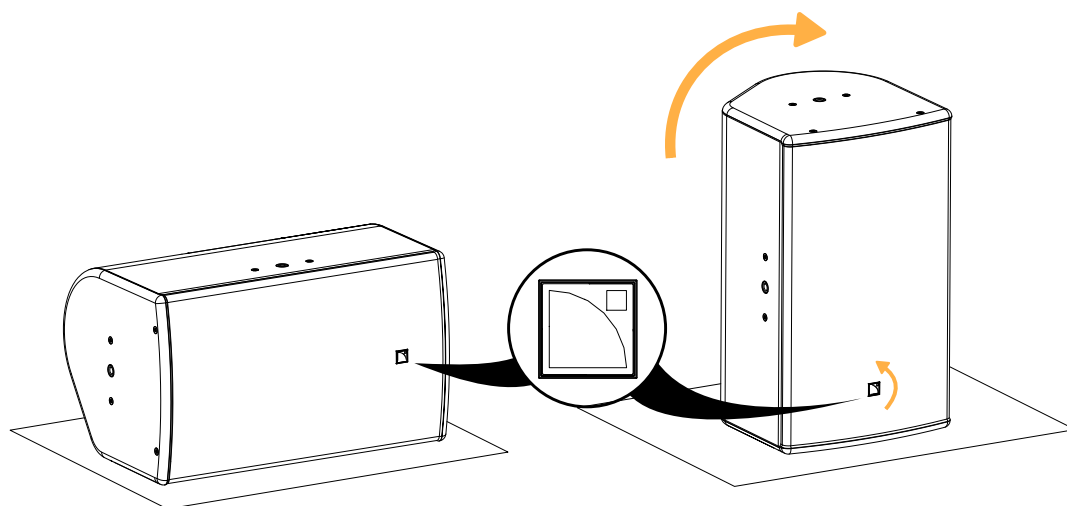

X8 features an ergonomic handle for easy transportation.

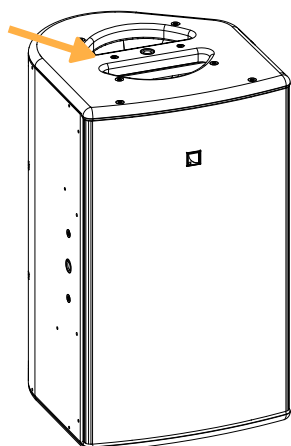

Elements for flying and wall-mounting

X-US8 and X-UL8

X8 can be fitted with a short U-bracket, X-US8, or a long U-bracket, X-UL8. The brackets are secured in the enclosure inserts with two threaded knobs. A spring-lock safety mechanism secures the knobs in the U-brackets.

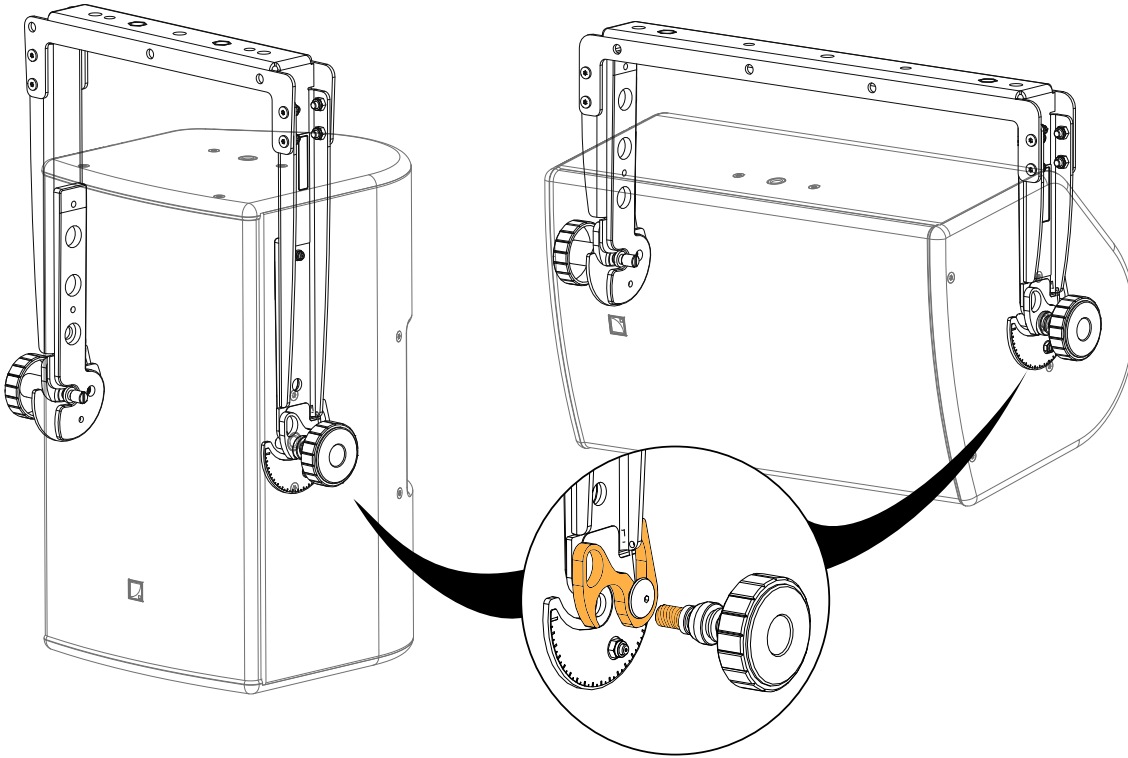

The threaded knobs feature a washer as a safety to avoid the accidental loosening of the knob.

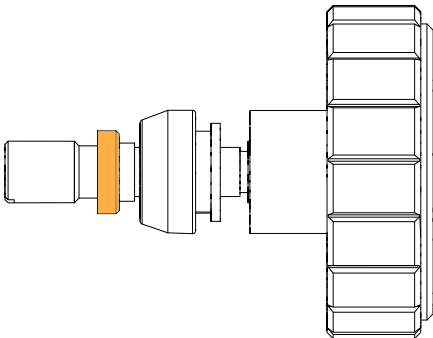

X-US8 and X-UL8 can be used for wall-mounting, ceiling-mounting or flying X8.



Short U-bracket in horizontal position

In this position, the enclosure applies a diagonal force of **179 daN** on the anchoring points.

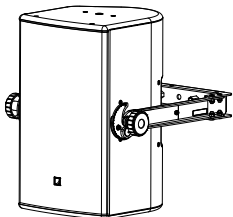

Fasteners for wall-mounting or ceiling-mounting

Secure the bracket with three M10 screws.

Select screw length and anchors applicable to the wall or ceiling properties.

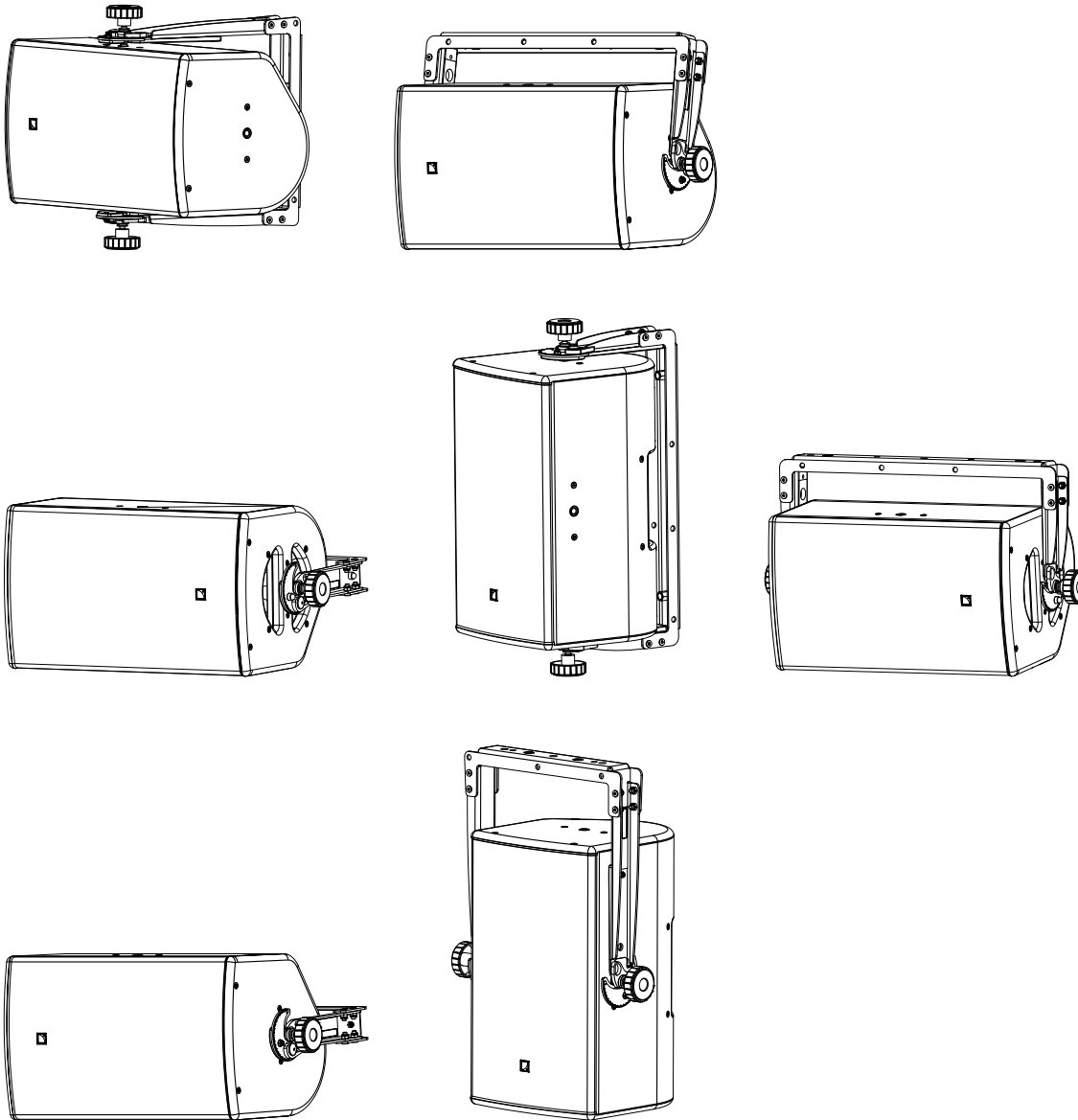

i When using the additional hole, consider the maximum site angle available.
 See [Maximum angles](#) (p.54).

X-US8 features an additional hole on the sides to closely fit the enclosure and to minimize visual impact.

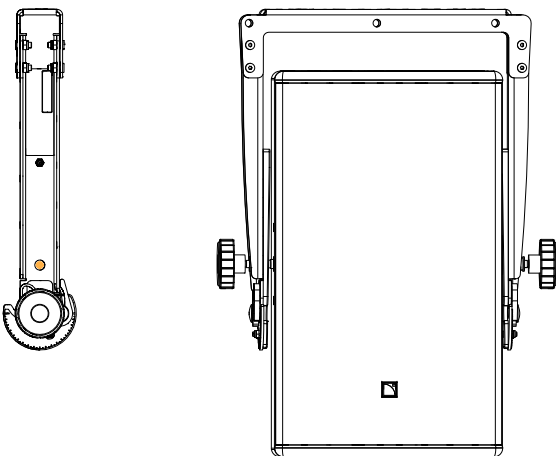

The knobs shall be stored in the U-brackets.

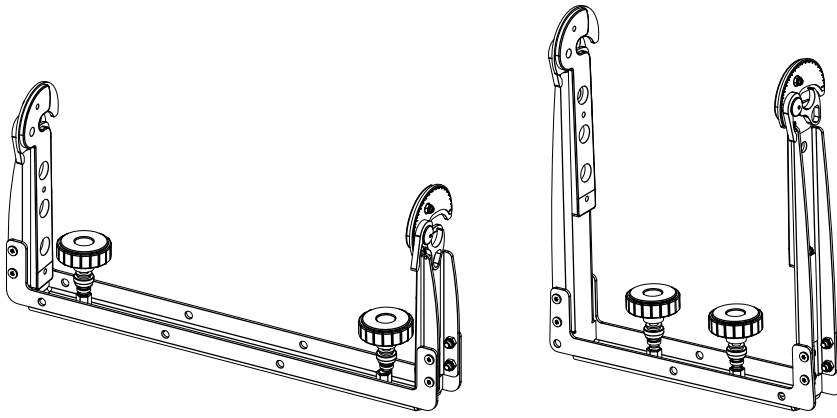

X-UL8i

X-UL8i is a long U-bracket for wall-mounting, ceiling-mounting, or flying X8 in fixed installation applications. It is secured to X8 with two M10 screws and washers (provided).



Fasteners for wall-mounting or ceiling-mounting

Secure the bracket with two M8 screws.

Select screw length and anchors applicable to the wall or ceiling properties.



X-UL8i is not compatible with X-UTILT.

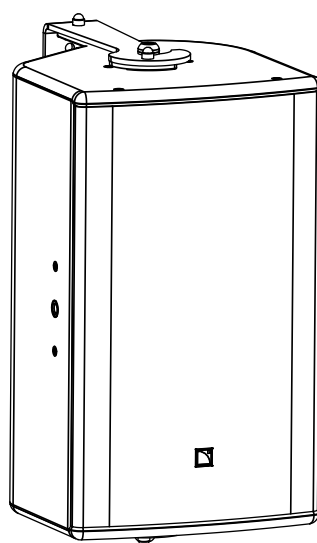
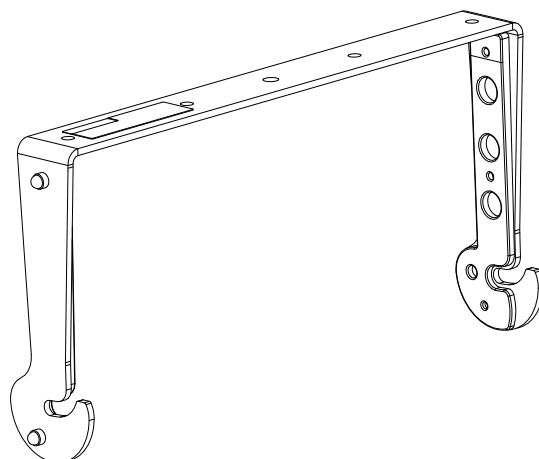

X-UTILT

X-UTILT is a tilt adjustment accessory compatible with X-US8 and X-UL8. X-UTILT provides negative site angle setting combined with azimuth angle setting capabilities in a wall-mount configuration. The site angle can be set from 0° to -45° in 5° steps. The azimuth angle can be adjusted with the U-bracket.

! X-UTILT intended use

Use X-UTILT only vertically and for negative site angles.

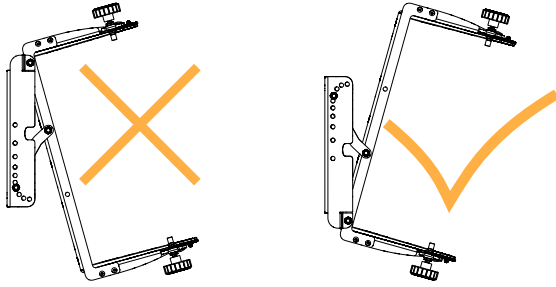

! Assembling X-UTILT with X-US8 or X-UL8

X-US8 and X-UL8 have three holes for assembling with X-UTILT. Use hole 1 (furthest from the label) to secure the U-bracket to X-UTILT, and hole 2 to secure the rigging arm. Hole 3 is reserved for storage (0° site angle).

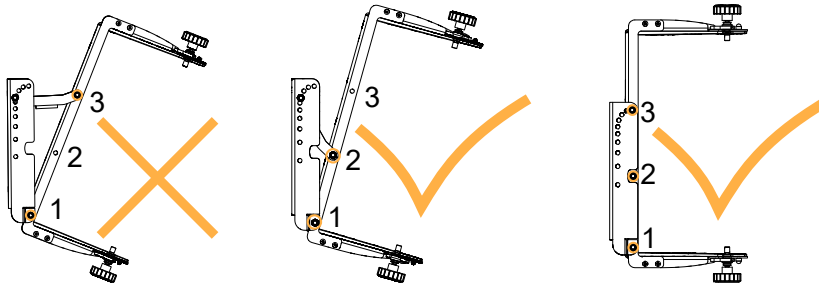

! When using X-US8, the bracket must be secured with the label on top.

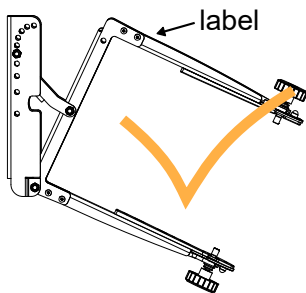

! Fasteners for wall-mounting

Secure X-UTILT with two M10 screws.

Select screw length and anchors applicable to the wall properties.

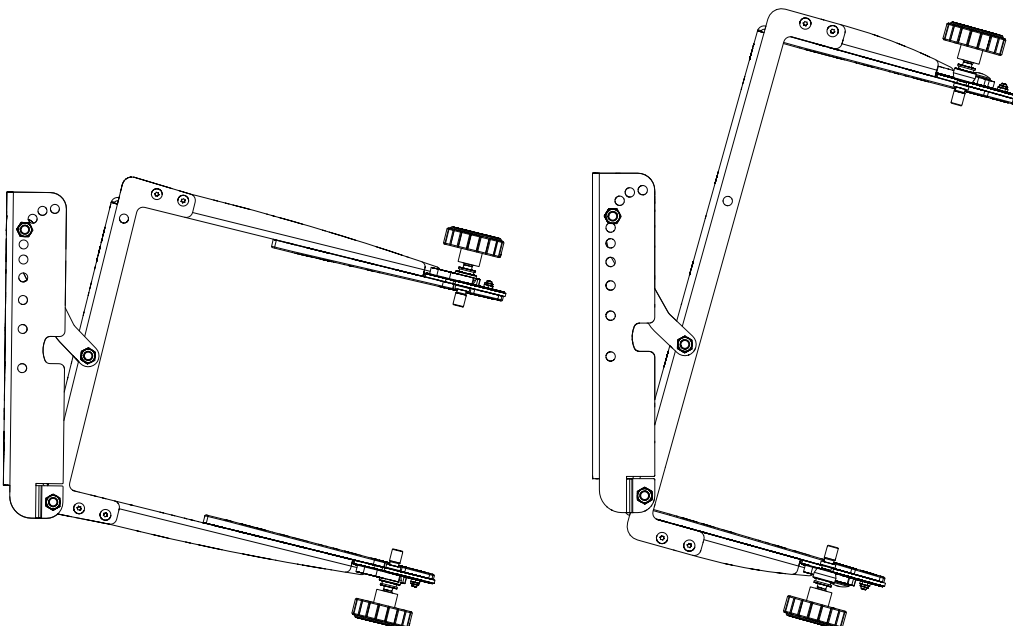

X-BAR

X-BAR is a rigging bar for flying X8. The rigging system consists of a threaded axis with a cam lever.

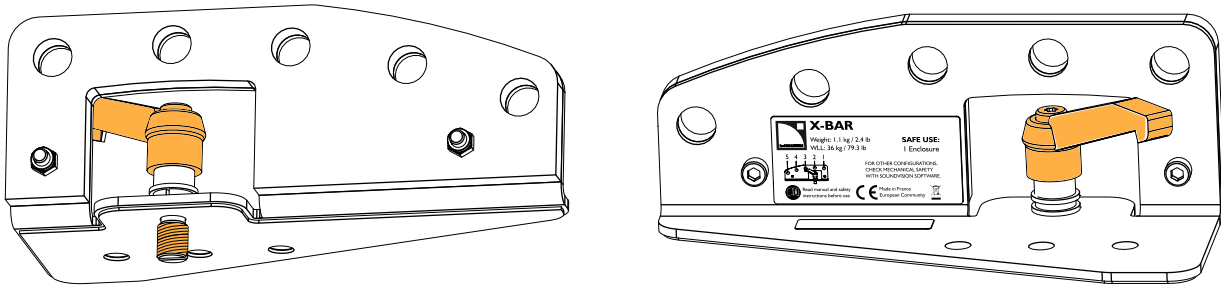

X-BAR is secured to the dedicated inserts on the enclosure, in front or rear extension position.

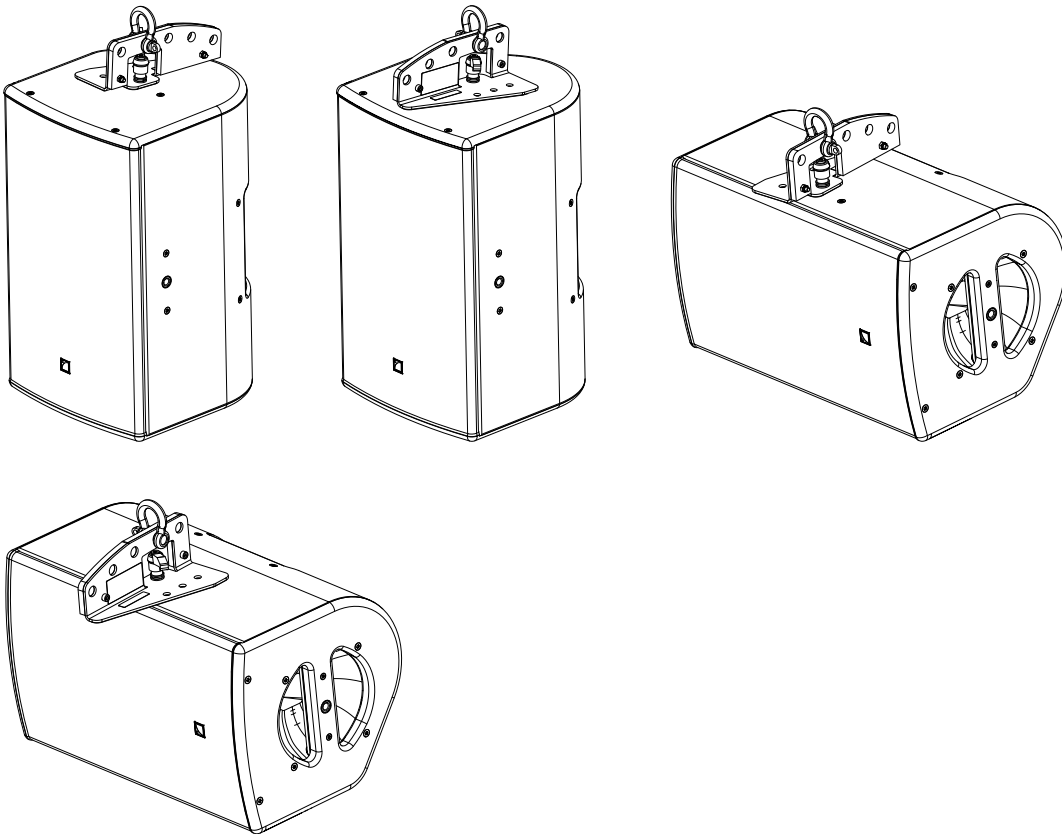

Five angulation holes are available.

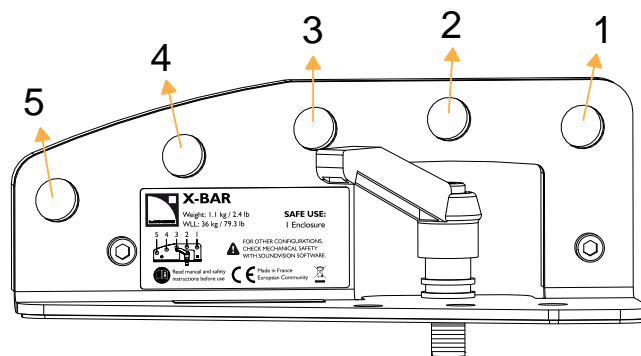

X-BAR is compatible with a Ø12 mm shackle WLL 1 t (provided) and with CLAMP250.

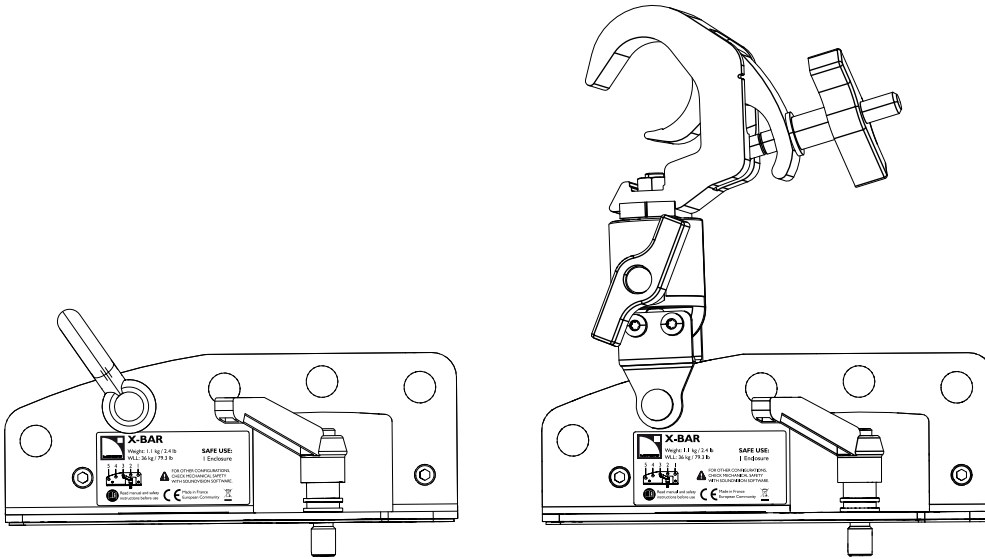

Elements for pole-mounting

Pole socket

X8 features a 35 mm pole socket integrated in the handle.

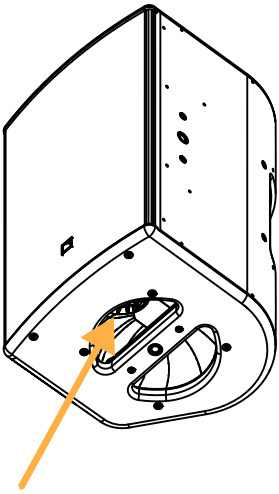

EMBi

EMBi is a pole-mount adapter for X-US8 (35 mm pole). The site angle can be adjusted with the U-bracket.



Risk of damaging the bracket safety mechanism

When using X-US8 and EMBi for pole-mounting X8, always use the additional holes on the bracket.

Do not use X-UL8 with EMBi.

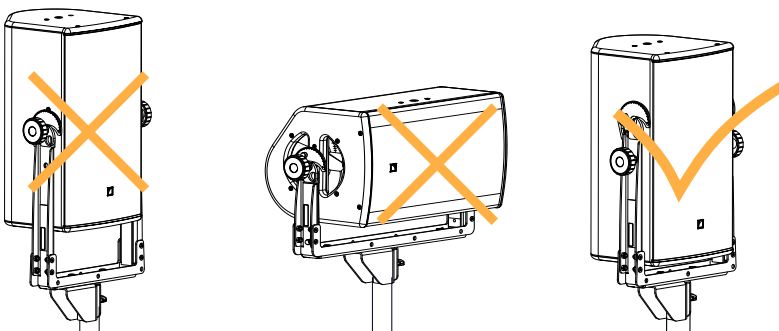



Do not use EMBi with X-UL8i.

In pole-mounting position, the screws are not maintained by the bracket hooks.

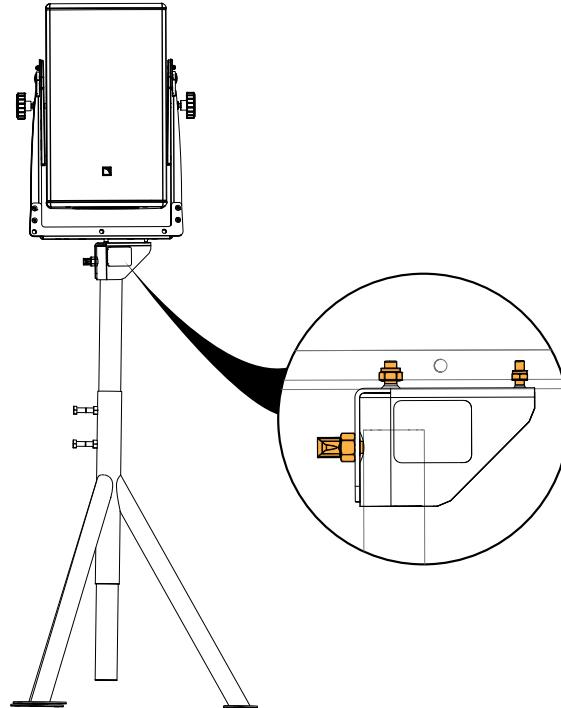
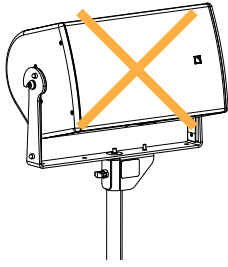

Subwoofer

SB15m features a 35 mm pole socket.

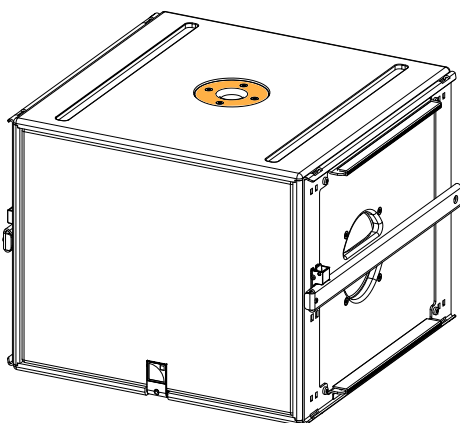

Mechanical safety

The X8 rigging system complies with EN 62368-1: 2014 Audio/video, information and communication technology equipment — Part 1: Safety requirements.

The deployments described in this manual achieve a safety factor of 5.

X8

Configuration	Rigging accessory	Maximum / Safe limit
Wall-mounted	X-US8 / X-UL8 + X-UTILT (optional)	1
	X-UL8i	1
Ceiling-mounted	X-US8 / X-UL8 / X-UL8i	1
Flown	X-US8 / X-UL8 / X-UL8i / X-BAR + CLAMP250 (optional)	1
Pole-mounted	35 mm pole + EMBi and X-US8 (optional)	1
Ground-stacked	No rigging accessory	1



Additional safety for flown arrays

When flying an enclosure, use the M8 DIN580 threaded insert to implement a secondary safety.

Loudspeaker configurations

X8 point source

Deployed as a standalone point source, an X8 system operates over the nominal bandwidth of the X8 enclosure.

The [X8] preset delivers a reference frequency response in short throw applications.

The X8 enclosure is driven by the LA4X / LA8 / LA12X amplified controllers.

Standalone X8

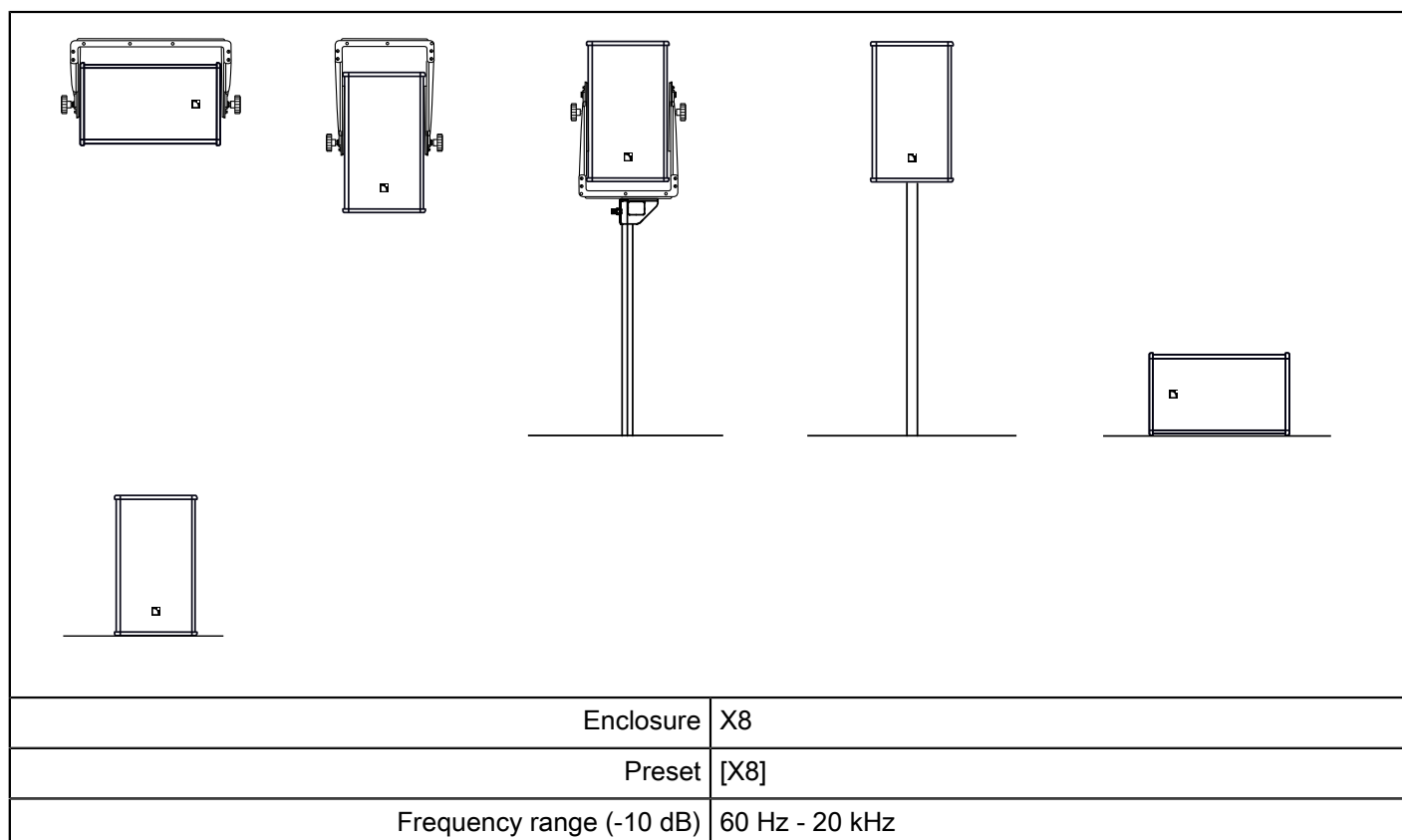

X8 point source with LF

Deployed as a point source with SB15m subwoofers, an X8 system operates with augmented LF resources.

The [X8] preset delivers a reference frequency response in short throw applications.

The [SB15_100] preset provides the SB15m with an upper frequency limit at 100 Hz for an optimal frequency coupling with X8.

The X8 and SB15m enclosures are driven by the LA4X / LA8 / LA12X amplified controllers.

X8 with SB15m

With SB15m, the X8 system contour is reinforced by 8 dB at 100 Hz and the bandwidth is extended down to 40 Hz.

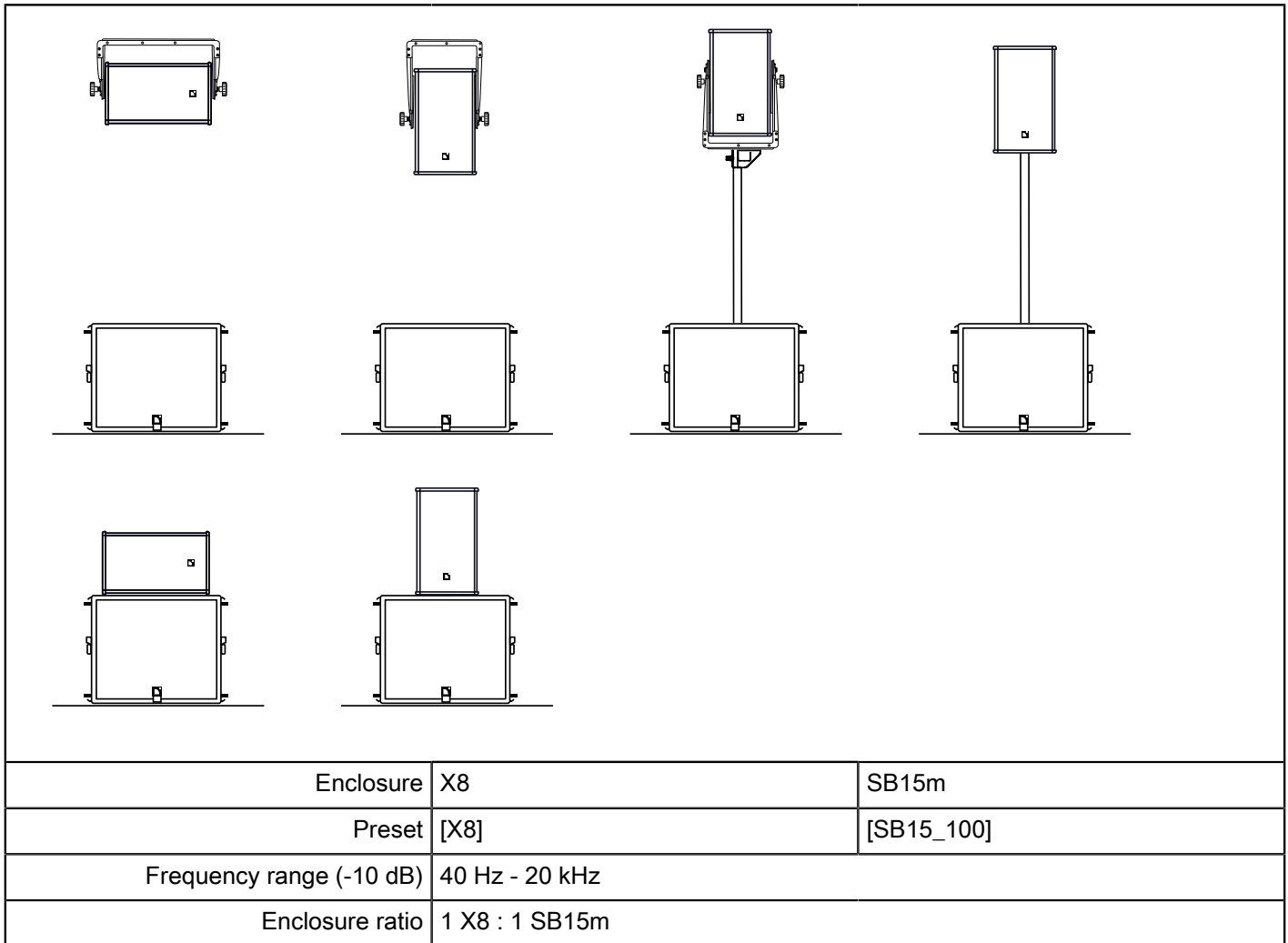

- !** **Grouping subwoofers**
Place the subwoofer enclosures side by side. If not possible, the maximum distance between two adjacent acoustic centers must be 1.7 m if the upper frequency limit of the subwoofer system is at 100 Hz.
- !** **Use [xxxx_xx_C] or [xxxx_xx_Cx] on a reversed subwoofer in a cardioid configuration**
The cardioid configuration consists in reversing 1 element in an array of 4 subwoofers.
Refer to the subwoofer owner's manual and to the **Cardioid configurations** technical bulletin.
- !** **Delay values**
Do not forget to add the pre-alignment and geometric delays depending on the configuration.

Pre-alignment delays

presets	pre-alignment delay values and polarity settings		
[X8] + [SB15_100]	X8 = 2 ms	<input style="background-color: #cccccc;" type="button" value="+"/>	SB15m = 0 ms <input style="background-color: #cc0000;" type="button" value="-"/>
[X8] + [SB15_100_C]	X8 = 5.7 ms	<input style="background-color: #cccccc;" type="button" value="+"/>	SB15m = 0 ms <input style="background-color: #cc0000;" type="button" value="-"/>
[X8] + [SB15_100_Cx]	X8 = 3.8 ms	<input style="background-color: #cccccc;" type="button" value="+"/>	SB15m = 0 ms <input style="background-color: #cc0000;" type="button" value="-"/>

X8 stage monitor

Deployed as a stage monitor, an X8 system operates over the nominal bandwidth of the X8 enclosure.

The [X8_MO] preset delivers a reference frequency response in stage monitoring applications.

The X8 enclosure is driven by the LA4X / LA8 / LA12X.

Standalone X8

<p>35°</p> 	
Enclosure	X8
Preset	[X8_MO]
Frequency range (-10 dB)	55 Hz - 20 kHz

Low-latency preset

A low-latency preset is available for the X8 enclosure used as a monitor ([X8_MO]). It reduces latency from 3.84 ms down to 1.18 ms (LA7.16i) and 0.84 ms (LA2Xi / LA4X / LA12X).

To combine the monitor with a subwoofer:

- on 4-channel amplified controllers, create a custom low-latency preset
- on 16-channel amplified controllers, select the low-latency (*_MO) preset for the subwoofer

Refer to the **LA Network Manager Help** for more information.

Paired X8 monitors with LFC

The Low Frequency Contour (LFC) tool implemented in LA Network Manager can compensate for coupling effects between closely operating monitors. LFC allows to adjust the frequency response curve to obtain the desired low frequency contour.

For paired X8 monitors, enter the following parameters to obtain the reference response curve of a single enclosure:

	LF Contour	N/A
FREQ/RATIO	180	
GAIN	-3.0	

For more information about LFC, refer to the **LA Network Manager Help** (section: Group Control Panel) and to the **Array Morphing** white paper, available on www.l-acoustics.com.

X8 stage monitor with LF

Deployed as a stage monitor with SB15m subwoofers, an X8 system operates with augmented LF resources.

The [X8_MO] preset delivers a reference frequency response in stage monitoring applications.

The [SB15_100] preset provides the SB15m with an upper frequency limit at 100 Hz for an optimal frequency coupling with the X8.

The X8 and the SB15m enclosures are driven by the LA4X / LA8 / LA12X amplified controllers.

X8 stage monitor with SB15m

With SB15m, the X8 system contour is reinforced by 8 dB at 100 Hz and the system bandwidth is extended down to 40 Hz.

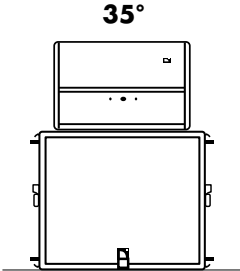
		
Enclosure	X8	SB15m
Preset	[X8_MO]	[SB15_100]
Frequency range (-10 dB)	40 Hz - 20 kHz	
Enclosure ratio	1 X8 : 1 SB15m	

! Delay values

Do not forget to add the pre-alignment and geometric delays depending on the configuration.

Pre-alignment delays

presets	pre-alignment delay values and polarity settings	
[X8_MO] + [SB15_100]	X8 = 0 ms <input style="float: right;" type="button" value="+"/>	SB15m = 3 ms <input style="float: right;" type="button" value="+"/>

! [xx_MO] presets (except for legacy XT and MTD enclosures) use the amplified controller low latency operating mode. When used along with subwoofers, it is recommended to use the subwoofers in low latency operating mode.

On 4-output amplified controllers, create custom presets combining low latency channel sets and subwoofer channel sets.

If the subwoofers are driven from a dedicated 4-output amplified controller using a subwoofer factory preset, they are operated in normal latency mode. Therefore, an additional delay should be set to the [xx_MO] low latency channels to align them: 2.66 ms on LA4 and LA8 or 3.00 ms on LA2Xi, LA4X, and LA12X.

Inspection and preventive maintenance

How to do preventive maintenance

Inspect the system before any deployment and after any corrective maintenance operation.

Perform preventive maintenance at least once a year.

Rigging and hardware

Perform the [Rigging part inspection](#) (p.27) on each rigging part.

Use the [Mechanical system overview](#) (p.29) to identify critical parts of the system and apply the specific checks described in the [Inspection references](#) (p.32).

If any parts are damaged, contact your L-Acoustics representative for further instructions.

Acoustics

Perform the [Enclosure check](#) (p.33).

Perform the [Listening test](#) (p.35) to detect any degradation in sound quality.

If necessary, refer to the [Corrective maintenance](#) (p.69) section for speaker repair kits and maintenance instructions.

Rigging part inspection

About this task

For critical rigging parts, use the [Inspection references](#) (p.32) for comparison and specific manipulations.

The term "rigging part" comprises:

- lifting accessories such as clamps and shackles
- rigging accessories such as rigging frames, rigging interfaces, and brackets
- fasteners used for assembling two products together such as ball-locking pins, rigging axes, rigging screws, threaded knobs, and safety pins

This inspection procedure covers only L-Acoustics products. To inspect other products that are part of the lifting chain, refer to the manufacturer's instructions.

Prerequisite

Perform the inspection in a well-lit environment.

Procedure

1. Check that the rigging part is present.
2. If applicable, disassemble the rigging part from the enclosure or the rigging accessory.

Check that the tethers are intact and safely secured.

3. Inspect the part from every side.

Compare with the **reference illustrations**.

Check for:

- corrosion
- wear and cracks
- bends and dents
- holes
- missing safety cues
- missing identification labels
- missing or loose fasteners



Replacing screws

If a screw is loose, remove and replace it.

Always use the new screws provided in the repair kit.

If no new screw is available, add blue threadlocker before reusing the screw.

Do not apply more than the indicated torque.

4. Check the **geometry** of the part to identify critical deformations.

Place the rigging part on a flat surface or hold a level against it.

5. Check the **moving parts**.



Make sure that the mechanism engages correctly.

What to do next

If a problem is detected, perform the authorized maintenance operations or contact your L-Acoustics representative.

Mechanical system overview

Critical parts of the lifting chains are highlighted.

The  indicates a visual inspection. The  indicates a functional check.

 Perform the [Rigging part inspection](#) (p.27) on critical parts.
For each part, refer to the [Inspection references](#) (p.32).

 **Replacing screws**
If a screw is loose, remove and replace it.
Always use the new screws provided in the repair kit.
If no new screw is available, add blue threadlocker before reusing the screw.
Do not apply more than the indicated torque.

X8 with X-UL8

The same instructions apply to X-US8.

the supporting screws are tightened

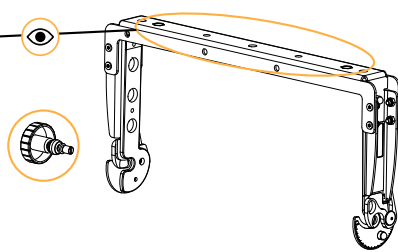

Threaded knobs (p.32)

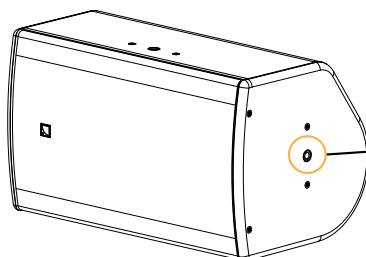

the inserts are not damaged

X8 with X-UL8i

the supporting screws are tightened

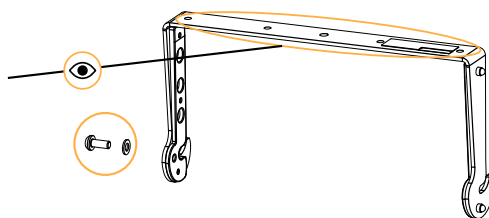

the washers are present
the screws are tightened

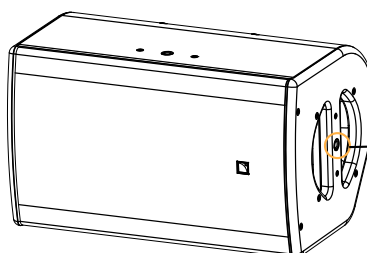

the inserts are not damaged

X8 with X-UL8 and X-UTILT

the inserts are not damaged

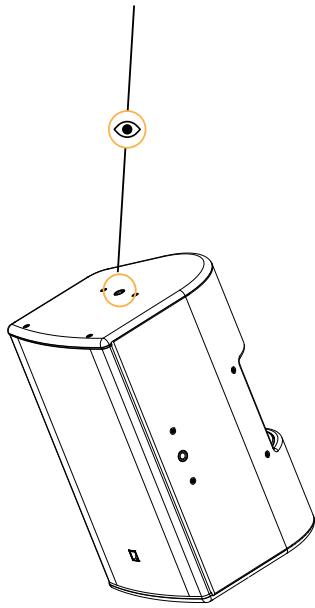

Threaded knobs (p.32)

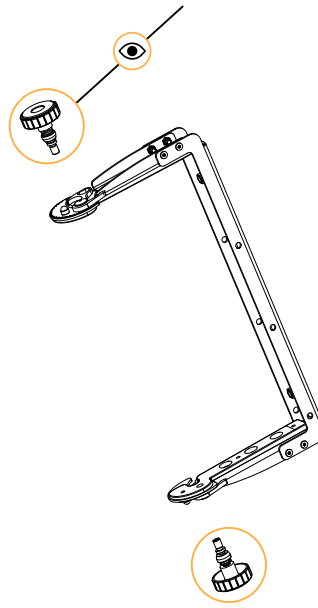

the supporting screws are tightened

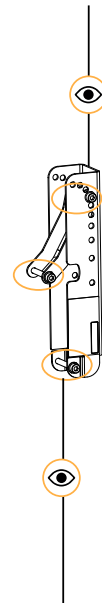

the axes are tightened and not bent

X8 with X-BAR and CLAMP250

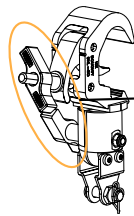

the wing knobs can be tightened and loosened by hand

pull up the lever and release it:

the lever returns to its initial position

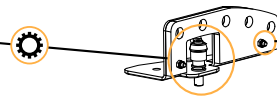

all screws are tightened

the top inserts are not damaged

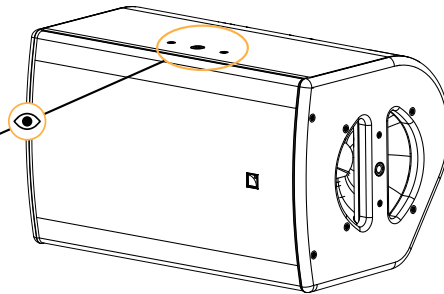

X8 pole-mounted

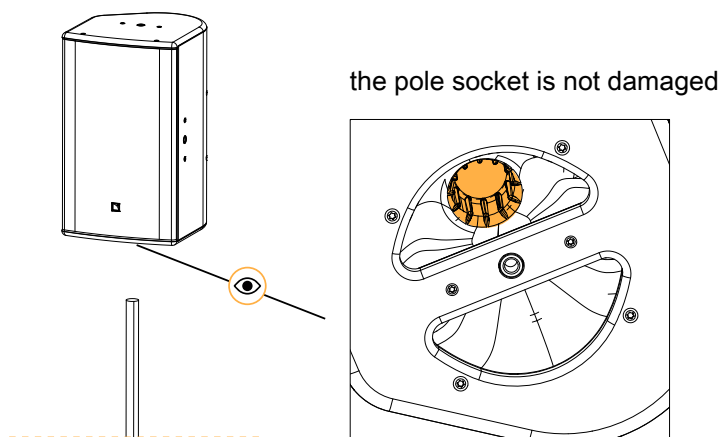

X8 pole-mounted with X-US8 and EMBi on SB15m

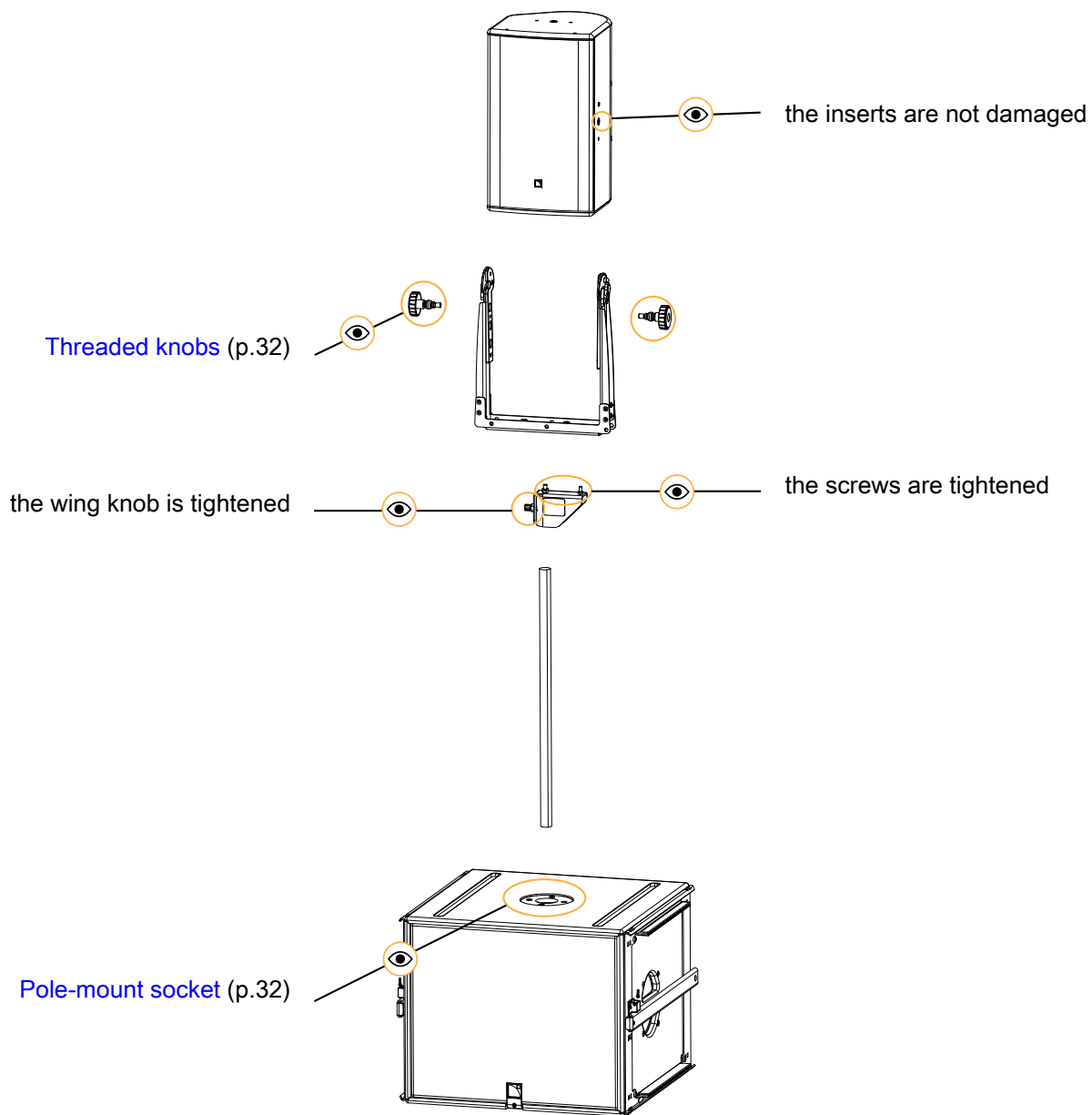

Inspection references

Threaded knobs

- Head part does not have cracks.
- Head part is tightly secured to the body part.
- All washers are present.

Reference illustrations

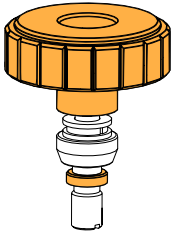

Related tasks

[Rigging part inspection](#) (p.27)

Pole-mount socket

- Pole-mount socket is not damaged or bent.
- Screws are tightened.
- Socket plug is present.

Reference illustrations

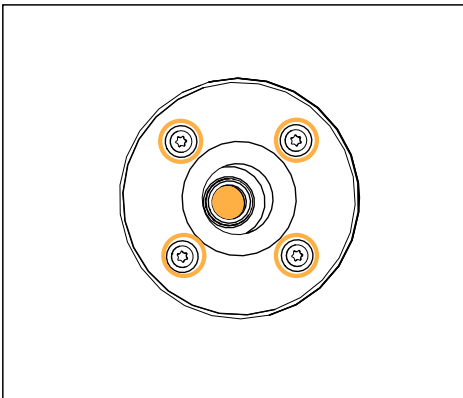

Contact your L-Acoustics representative for repair instructions.

Related tasks

[Rigging part inspection](#) (p.27)

Acoustical check

Enclosure check



This feature is available on:

LA4X
LA12X

ENCLOSURE CHECK measures impedance at the reference frequencies for the connected loudspeaker family. The test compares the measured impedance against the typical reference value for fast detection of loudspeakers with continuity issues.



The results can be used for preliminary diagnosis but cannot replace a comprehensive quality control.

Prerequisite



ENCLOSURE CHECK measurements can only be reliable if the following requirements are met:

Environment and temperature:

- Ambient temperature must be comprised between 0 °C / 32 °F and 40 °C / 104 °F. Ideal temperature is 20 °C / 68 °F.
- Enclosures must be at room temperature. If warm from a recent high level use or recently moved from a cold environment, let the loudspeakers reach room temperature before starting.

Enclosures:

- Enclosures must be included in the embedded factory preset or layout library.
- Enclosures must be in nominal operating conditions:
 - Remove covers or dollies obstructing the loudspeakers or the vents.
 - Check for obvious physical damage or air leak: visually inspect the grill, gasket, cabinet, and connector plate for loose, missing or damaged parts.

Connection:

- Use only 10 m / 30 ft 4 mm² / AWG 11 speaker cables.
- Do not connect enclosures in parallel.

Amplified controllers:

- LA4X must run at least firmware version 1.1.0.
- LA4X load sensors must be calibrated. Refer to the **Load Sensor Calibration Tool** technical bulletin for more information.
- LA4X must warm up for at least 10 minutes after power up. Do not power off, reboot or switch to standby mode to avoid resetting the countdown.
- Load a preset or a layout corresponding to the connected loudspeaker's family. Presets from the user memories may be used on condition they are made of presets supported in the embedded factory preset library.

Procedure

1. Power up the amplified controller. Let LA4X warm up for at least 10 minutes.
2. Connect the loudspeaker enclosures to the amplified controller.
3. Load a preset or a layout from (or built from) the embedded library and corresponding to the connected loudspeaker family.
4. On the amplified controller, select **MONITORING & INFO**.
5. Select **ENCLOSURE CHECK**.



Beware of sound levels.

Although the sound pressure levels generated for the ENCLOSURE CHECK are moderate, do not stay within close proximity of the loudspeakers and consider wearing ear protection.

6. Launch the ENCLOSURE CHECK.

The amplified controller generates short sinusoidal signals simultaneously for each connected output.

The amplified controller displays the results for each output.

7. Depending on the displayed results, follow the instructions in the table.

result	interpretation	instructions
OK	measured impedance is close to the reference value	enclosure is in working order electrically
?	unsupported preset family	only supported enclosures should be tested
NC	Not Connected	if cables are connected: a. inspect the cables and connections b. go to step 8 (p.34)
NOK	measured impedance is too different from the typical reference value	a. check that all the prerequisites are met, in particular that the loaded preset or layout corresponds to the connected speaker's family b. inspect the cables and connections c. go to step 8 (p.34)
UNDEF / UNDF	measured impedance is undefined	

8. Select each output with a NC, NOK, or UNDEF / UNDF result.

The amplified controller displays:

- the tested frequencies,
- information on the measured impedance:
 - OPEN for open circuit (found in NC results),
 - SHORT for short circuit (found in NOK results), or
 - a percentage of variation from the typical reference value (found in NOK and UNDEF / UNDF results)
- the number of operational transducers out of the total

 Low variations from the typical reference value are acceptable: displayed percentage can be different from 0 and all transducers considered operational. These variations can be caused by the room temperature being different from the ideal 20 °C / 68 °F, and by component or cable tolerances.

Listening test

enclosure	preset	usable bandwidth
X8	[X8]	60 Hz - 20 kHz

Procedure

1. Load the preset on an LA4X / LA8 / LA12X amplified controller.
2. Connect a sine wave generator to the amplified controller.



Risk of hearing damage

Set a low sound level to start and use ear protection to adjust before testing.

3. Scan the bandwidth focusing on the usable range.
The sound should remain pure and free of unwanted noise.

Troubleshooting for LF speakers

One or more LF speaker produces distorted, buzzing, rubbing, clicking, muffled or weak sound.

Possible causes

- The screws are not tightened with the appropriate torque.
- There is an air leak in the gasket.
- There is dust on the cone.
- The cone is damaged.
- The surround is torn or delaminated.
- The voice coil or the spider is damaged.

Procedure

1. Perform the speaker disassembly procedure.
2. Visually inspect the cables and the connectors.
3. Visually inspect the speaker cone, the voice coil and the spider.

If any damage is visible, replace the speaker.

4. Carefully clean the speaker with a dry cloth.
5. Perform the reassembly procedure.
Replace the speaker gasket and the screws.
Apply the recommended torque.
6. Repeat the listening test.

If the problem persists, replace the speaker.

Troubleshooting for HF drivers

One or more HF driver produces high-frequency harmonic distortions, strange vibrations or weak sound.

Possible causes

- There are foreign particles on the air gap.
- The diaphragm is not centered correctly.
- The screws used for reassembly are too loose.
- The diaphragm is damaged.
- The number of shims is wrong.

Procedure

1. Perform the diaphragm disassembly procedure.
2. Visually inspect the diaphragm and the voice coil.
If any damage is visible, replace the diaphragm.
3. Clean the air gap thoroughly.
Use double-face adhesive tape to remove any particles.
4. Perform the diaphragm reassembly procedure.
Pay close attention to the number of shims and the position of the diaphragm.
Apply the recommended torque.
5. Repeat the listening test.
If the problem persists, replace the driver.

Rigging procedures

Wall-mounting and ceiling-mounting

Mounting on X-US8 or X-UL8

type of deployment	wall-mounting
	ceiling-mounting
rigging accessories	X-US8 or X-UL8
additional material	3 × M10 screws and anchors
	electric screwdriver
min number of operators	1 or 2

! Additional safety for flown arrays
When flying an enclosure, use the M8 DIN580 threaded insert to implement a secondary safety.

! Ceiling-mounting
Additional holes on the short U-bracket can be used for optimal visual impact.
In this case, the rigging procedure will require 2 operators.

! Short U-bracket in horizontal position
In this position, the enclosure applies a diagonal force of **179 daN** on the anchoring points.

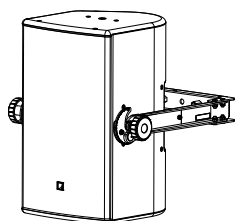

! Fasteners for wall-mounting or ceiling-mounting
Secure the bracket with three M10 screws.
Select screw length and anchors applicable to the wall or ceiling properties.

i The procedure is shown with X-UL8 in horizontal position.
The same procedure applies for X-UL8 in vertical position or in ceiling-mounting configuration and X-US8 in horizontal or vertical position or in ceiling-mounting configuration.

Assembly

Procedure

1. Drive the knobs in the inserts on the enclosure.
Stop when the threading is halfway in.

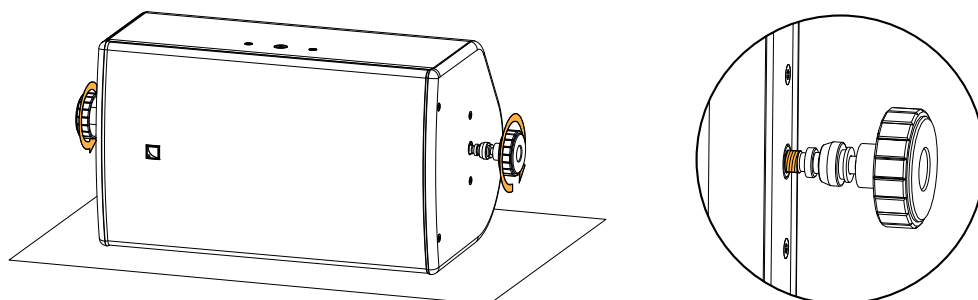



When securing the U-bracket horizontally, make sure the hooks are oriented upwards.



Fasteners for wall-mounting or ceiling-mounting

Secure the bracket with three M10 screws.

Select screw length and anchors applicable to the wall or ceiling properties.

2. Secure the U-bracket to the wall using M10 screws.

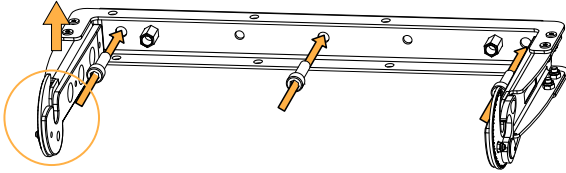

3. Lift the enclosure by the knobs and place it inside the U-bracket.

Adjust the knobs on both sides so that the safety washer is between the hook and the enclosure.

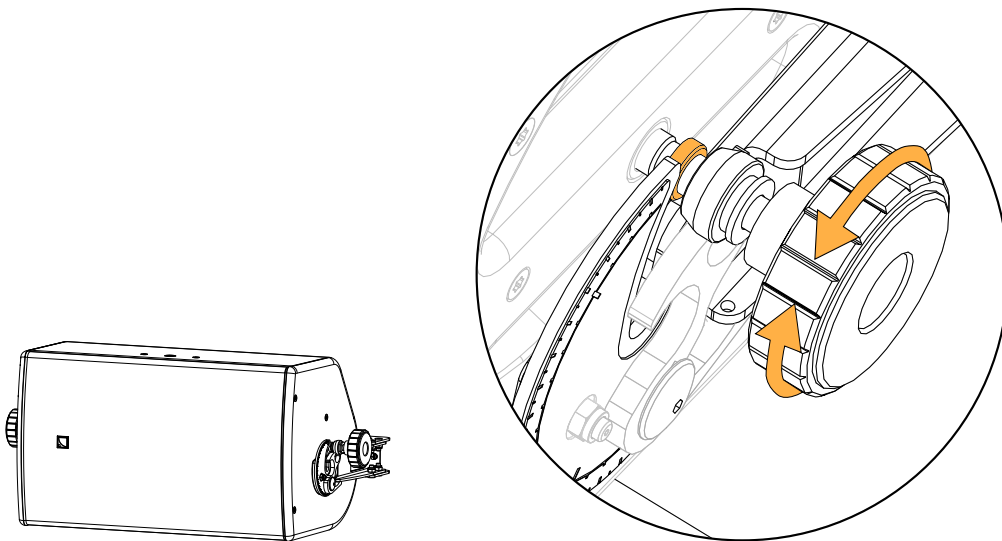

4. Push until the knobs are locked inside the spring-lock safety mechanism.

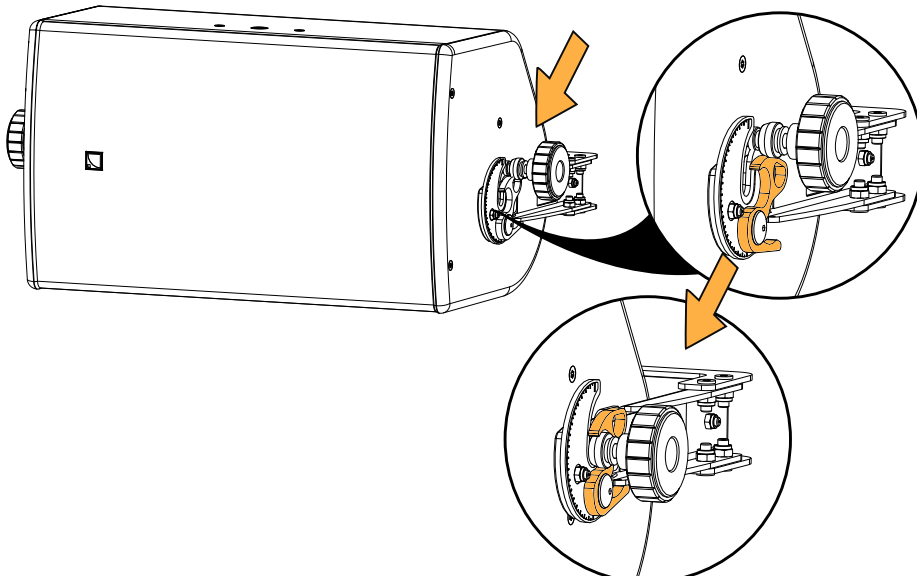

SHLAK!

5. Set the site angle.

Use the screw as a reference point to read the label.

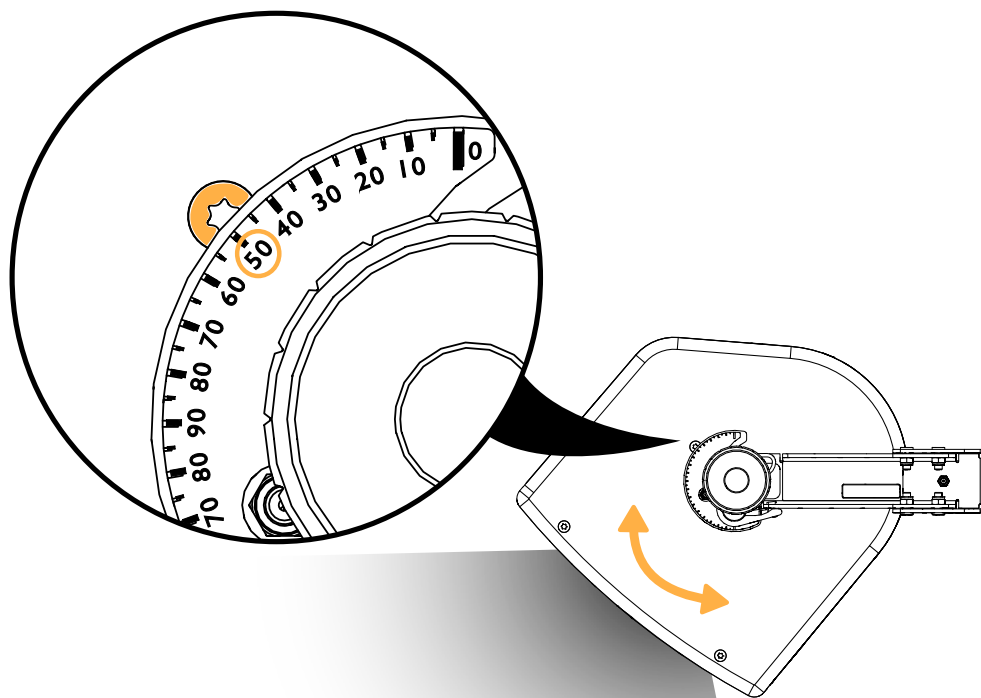
**6. Tighten the knobs.**

Make sure the enclosure is steady.

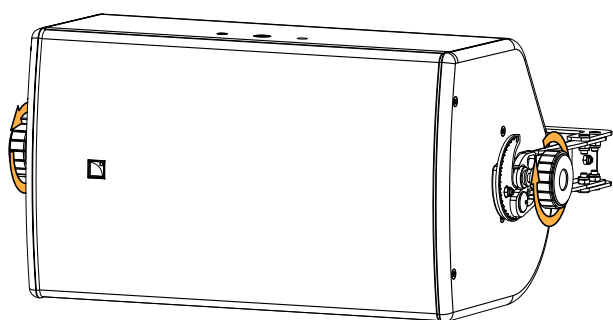

Disassembly

Procedure

1. Loosen the knobs until the enclosure can rotate freely.



Do not unscrew the knobs all the way.

2. On both sides, pull on the safety mechanism while lifting the enclosure by the knobs to release it.

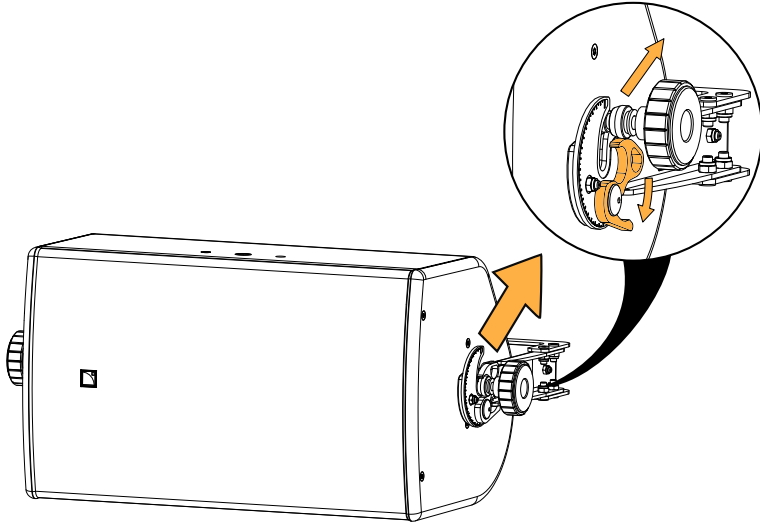

3. Remove the U-bracket from the wall.

Using X-US8 or X-UL8 with X-UTILT

type of deployment	wall-mounting
rigging accessories	X-US8 or X-UL8
	X-UTILT
additional material	2 x M10 screws
	electric screwdriver
min number of operators	1

Additional safety for flown arrays

When flying an enclosure, use the M8 DIN580 threaded insert to implement a secondary safety.

X-UTILT intended use

Use X-UTILT only vertically and for negative site angles.

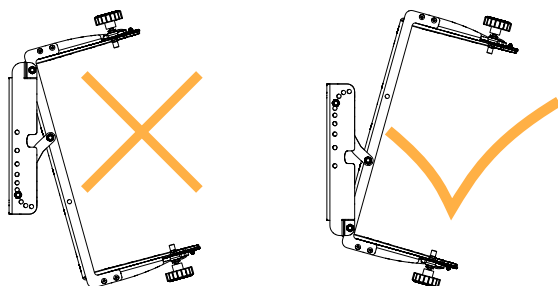

Fasteners for wall-mounting

Secure X-UTILT with two M10 screws.

Select screw length and anchors applicable to the wall properties.

The procedure is shown with X-UL8

The same procedure applies for X-US8.

Assembly

Procedure

1. Secure X-UTILT to the wall using M10 screws.

Position X-UTILT with the holes for angle selection at the top.

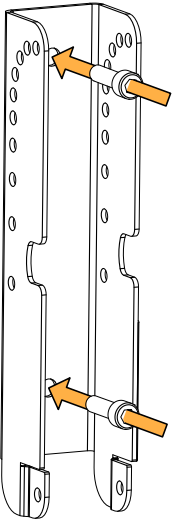

2. Secure the U-bracket to X-UTILT.



When using X-US8, the bracket must be secured with the label on top.

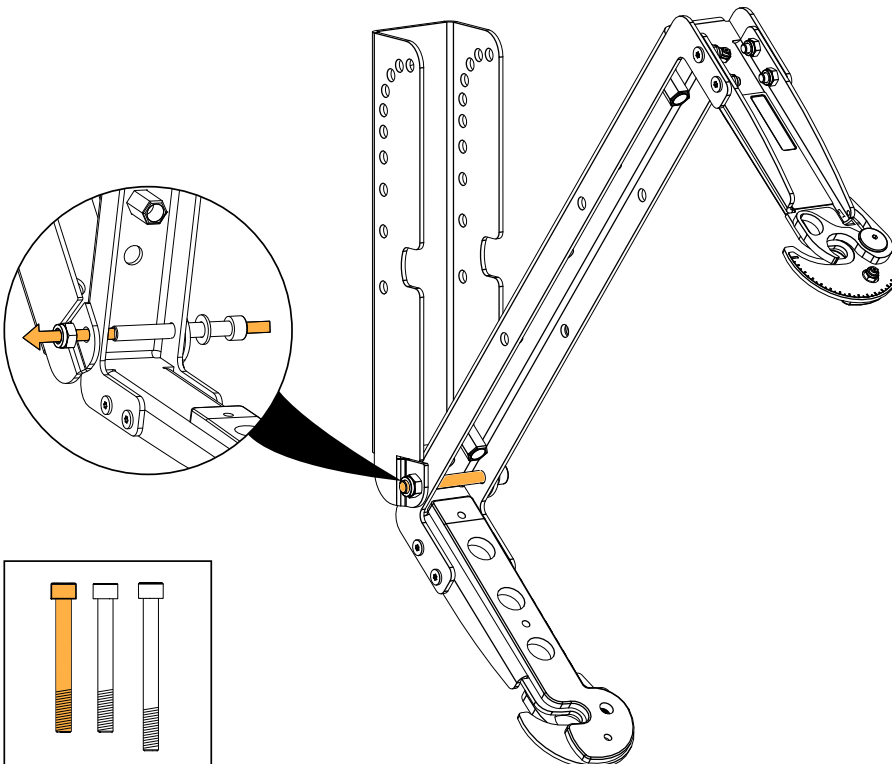
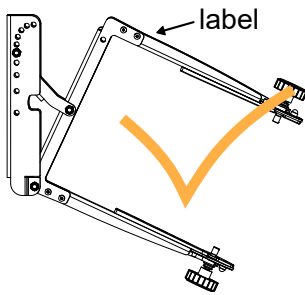

3. Secure the rigging arm to the U-bracket.

! Make sure the rigging arm is in the correct position.

! **Assembling X-UTILT with X-US8 or X-UL8**

X-US8 and X-UL8 have three holes for assembling with X-UTILT. Use hole 1 (furthest from the label) to secure the U-bracket to X-UTILT, and hole 2 to secure the rigging arm. Hole 3 is reserved for storage (0° site angle).

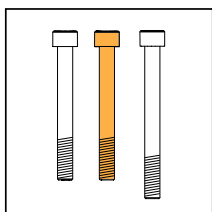
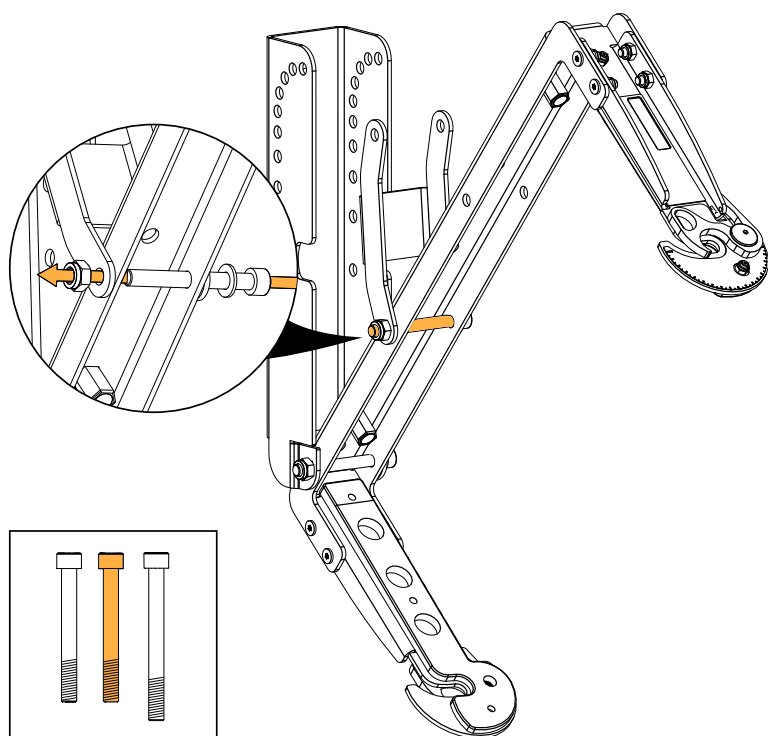
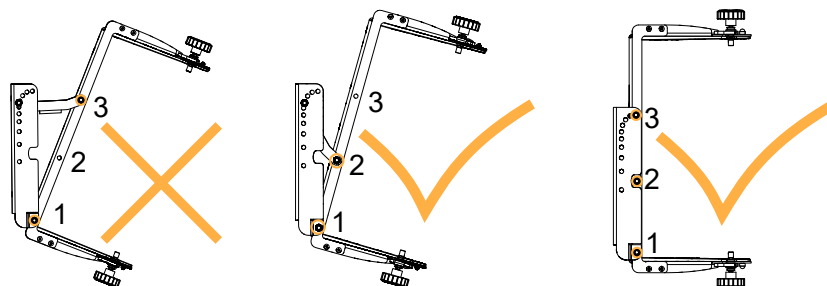

4. Choose the site angle and secure the rigging arm to X-UTILT.

Refer to the angles on the label.

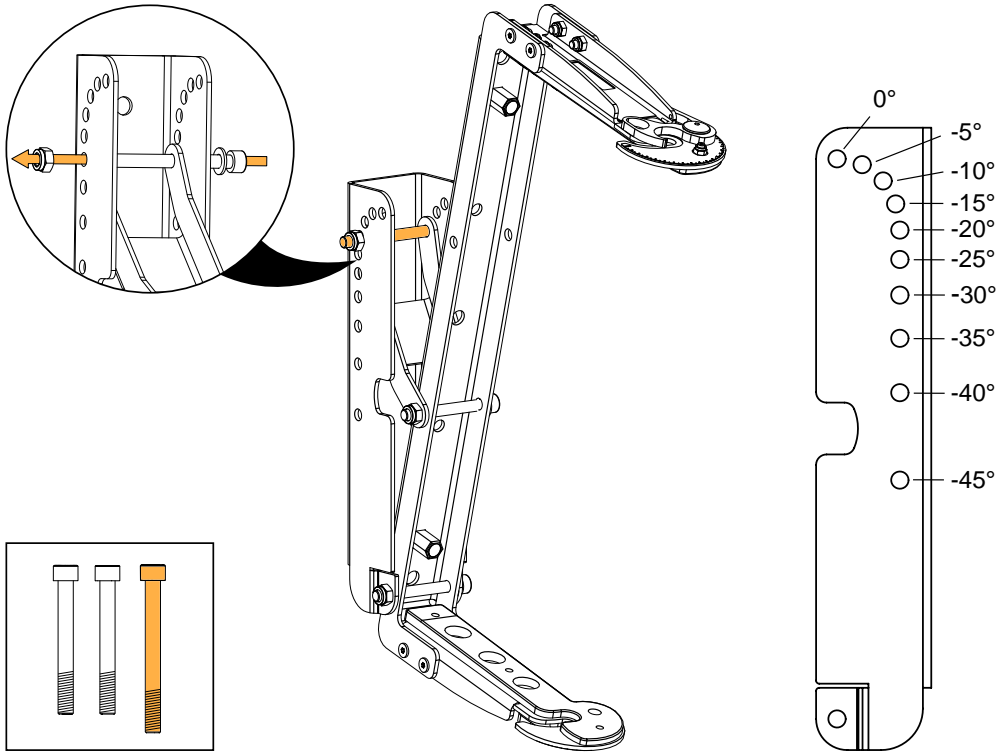

5. Drive the knobs in the inserts on the enclosure.

Stop when the threading is halfway in.

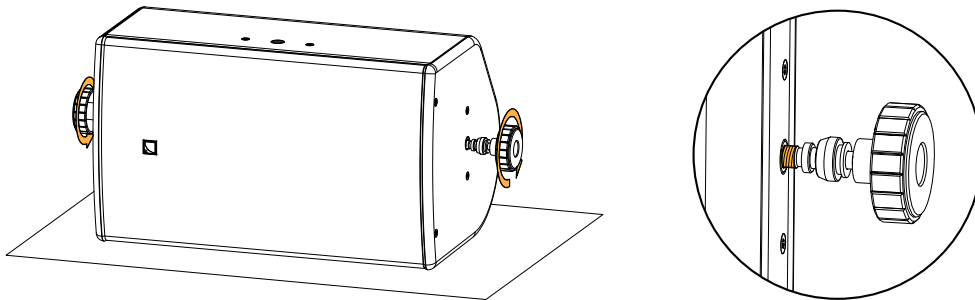

6. Lift the enclosure by the knobs and place it inside the U-bracket.

Adjust the knobs on both sides so that the safety washer is between the hook and the enclosure.

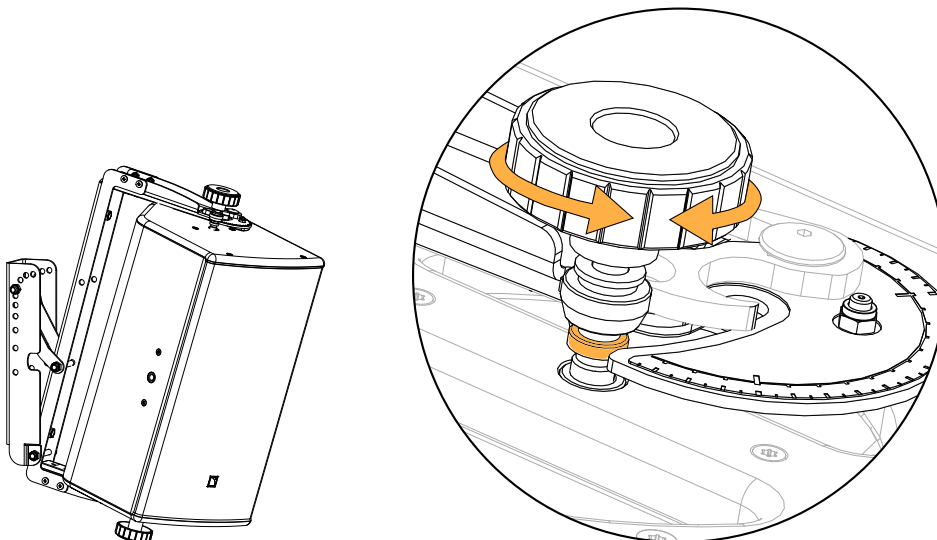

7. Push until the knobs are locked inside the spring-lock safety mechanism.

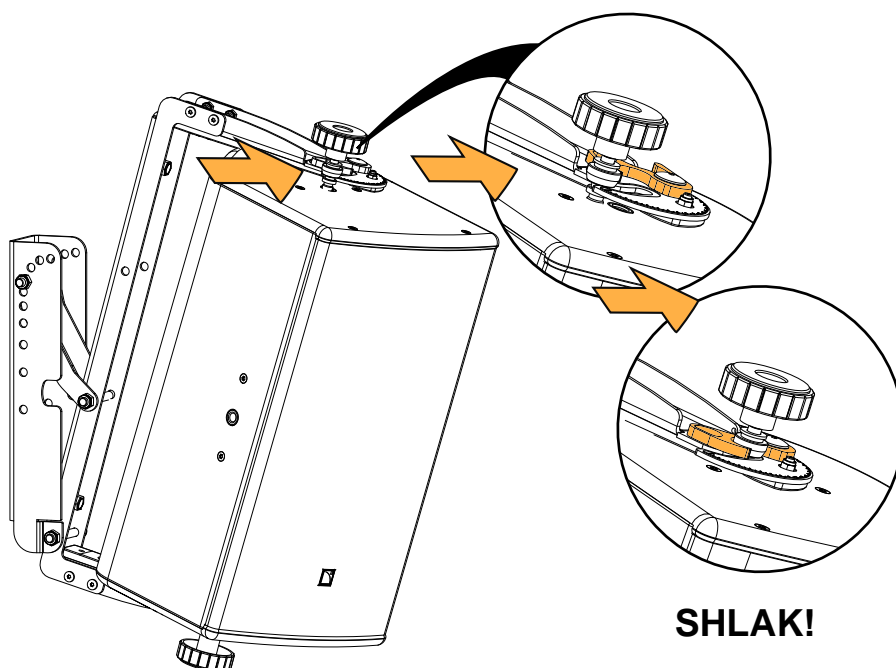

8. Set the azimuth angle.

Use the screw as a reference point to read the label.

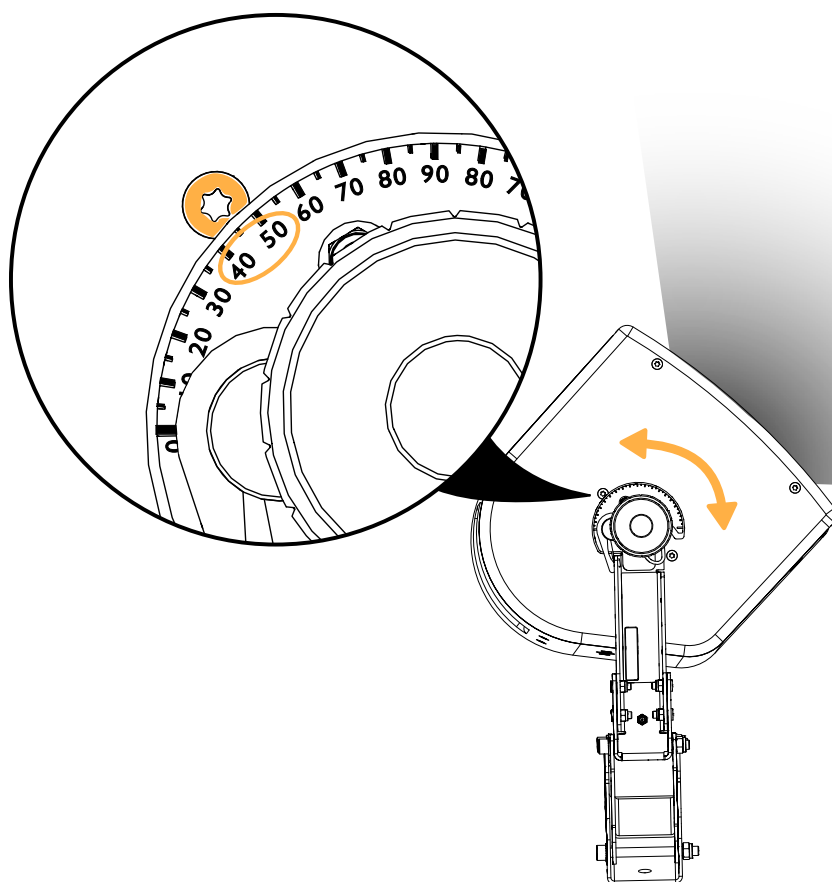

9. Tighten the knobs.

Make sure the enclosure is steady.

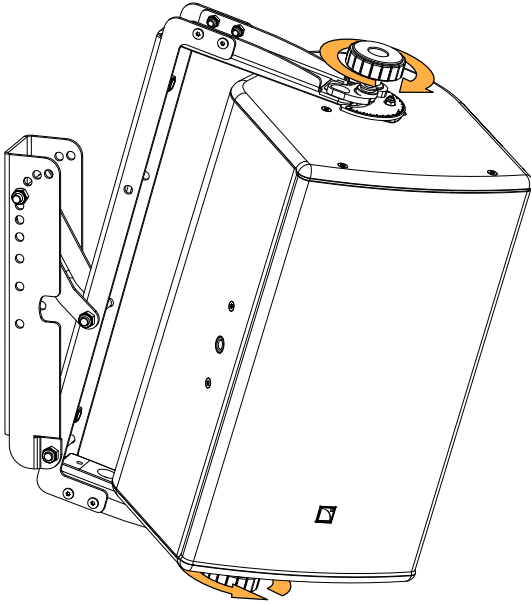

Disassembly

Procedure

1. Loosen the knobs until the enclosure can rotate freely.



Do not unscrew the knobs all the way.

2. On both sides, pull on the safety mechanism while sliding the enclosure out of the U-bracket.

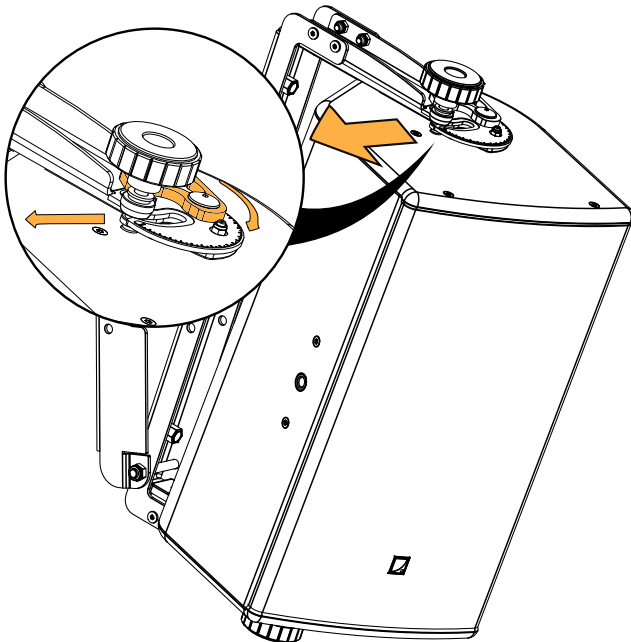

3. Remove the U-bracket and X-UTILT from the wall.

Mounting on X-UL8i

type of deployment	wall-mounting
	ceiling-mounting
rigging accessories	X-UL8i
	2 × M10 screws and washers (provided)
additional material	2 × M8 screws and anchors
tools	electric screwdriver with torque selector
	T50 Torx bit
min number of operators	1

! **Additional safety for flown arrays**
When flying an enclosure, use the M8 DIN580 threaded insert to implement a secondary safety.

! **Fasteners for wall-mounting or ceiling-mounting**
Secure the bracket with two M8 screws.
Select screw length and anchors applicable to the wall or ceiling properties.

i **The procedure is shown with X-UL8i in vertical position.**
The same procedure applies for X-UL8i in horizontal position or in ceiling-mounting configuration.

Assembly

Procedure

1. Drive the M10 screws with washers in the inserts on the enclosure.
Stop when the threading is halfway in.

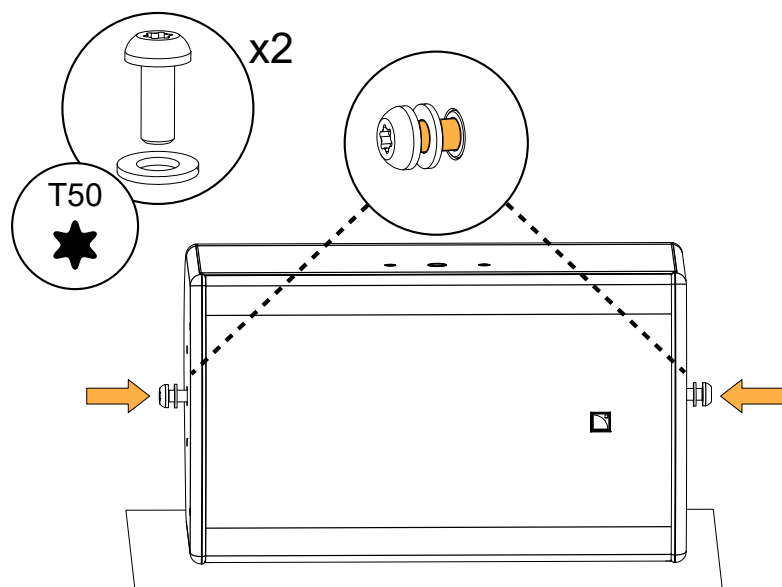



When securing the U-bracket horizontally, make sure the hooks are oriented upwards.



Fasteners for wall-mounting or ceiling-mounting

Secure the bracket with two M8 screws.

Select screw length and anchors applicable to the wall or ceiling properties.

2. Secure the U-bracket to the wall using two M8 screws.

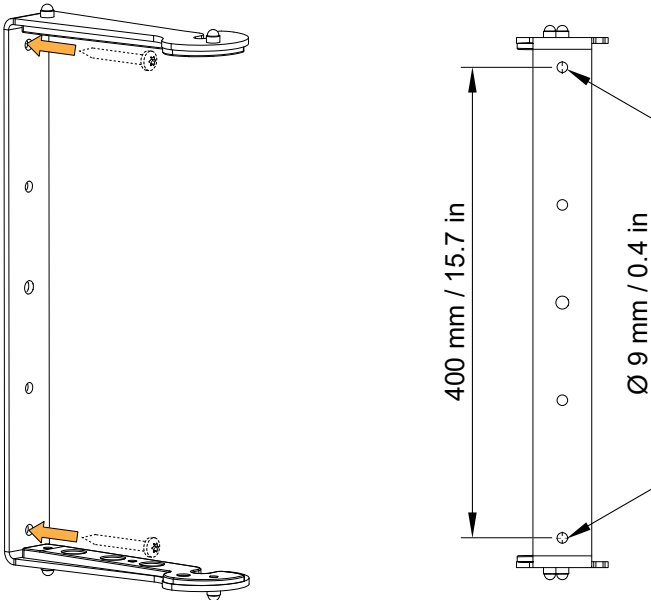

3. Lift the enclosure and place it inside the U-bracket.

Place the washers between the screw heads and the hooks.

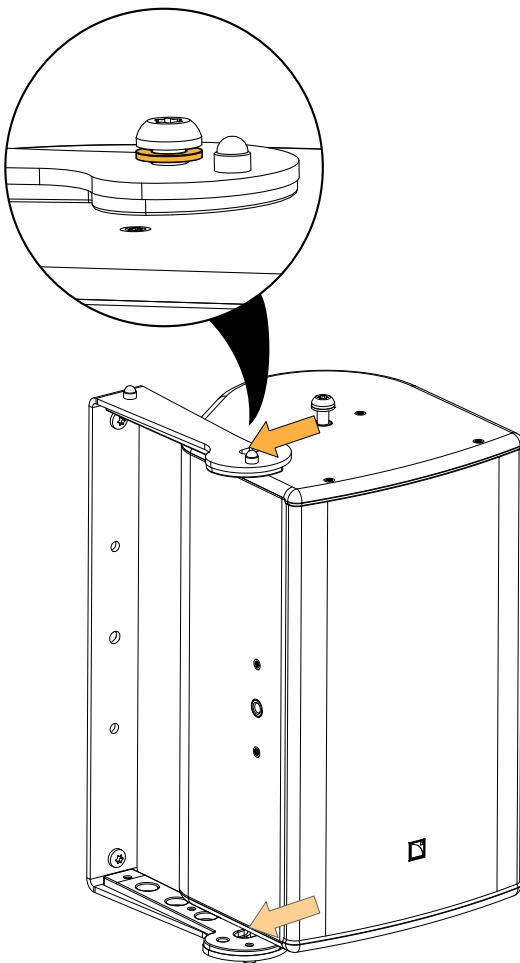

4. Set the azimuth or site angle.

Use a digital level or an inclinometer if necessary.

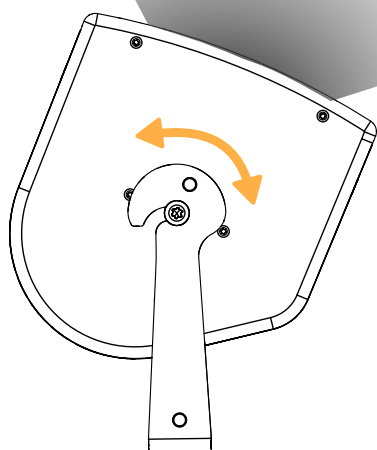
**5. Tighten the screws.**

Apply a 7 N.m. torque. Make sure the enclosure is steady.

Flying

Flying with X-US8 or X-UL8

type of deployment	flying
rigging accessories	X-US8 or X-UL8
additional material	M10 (3/8") truss clamp
min number of operators	1

Additional safety for flown arrays

When flying an enclosure, use the M8 DIN580 threaded insert to implement a secondary safety.

The procedure is shown with X-US8.

The same procedure applies for X-UL8.

Assembly

Procedure

1. Drive the knobs in the inserts on the enclosure.
Stop when the threading is halfway in.

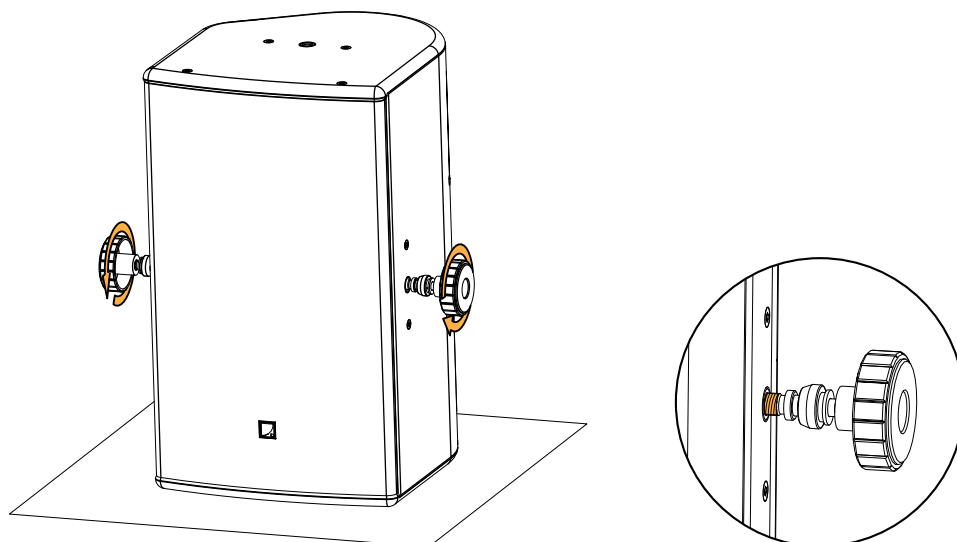

2. Place the U-bracket around the assembly.

Adjust the knobs on both sides so that the safety washer is between the hook and the enclosure.

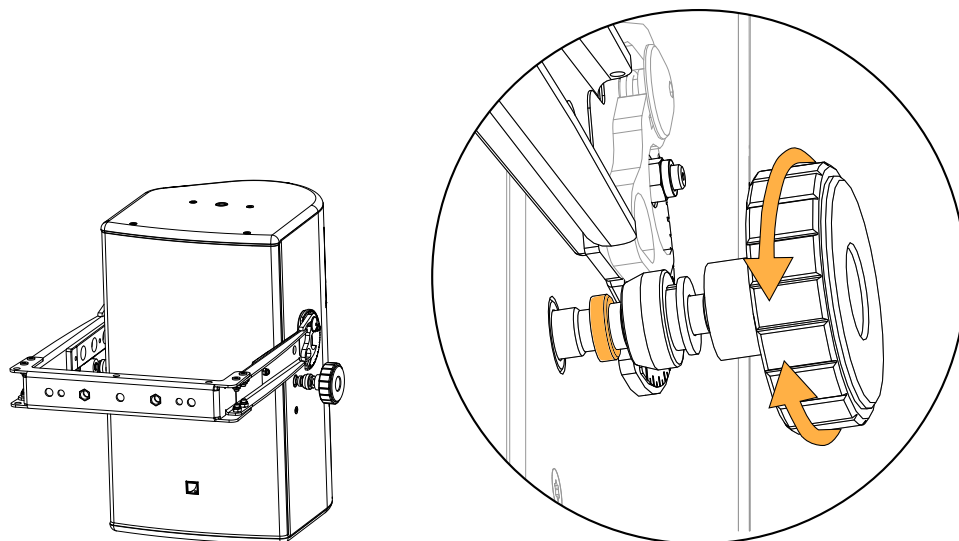

3. Push down until the knobs are locked inside the spring-lock mechanism.

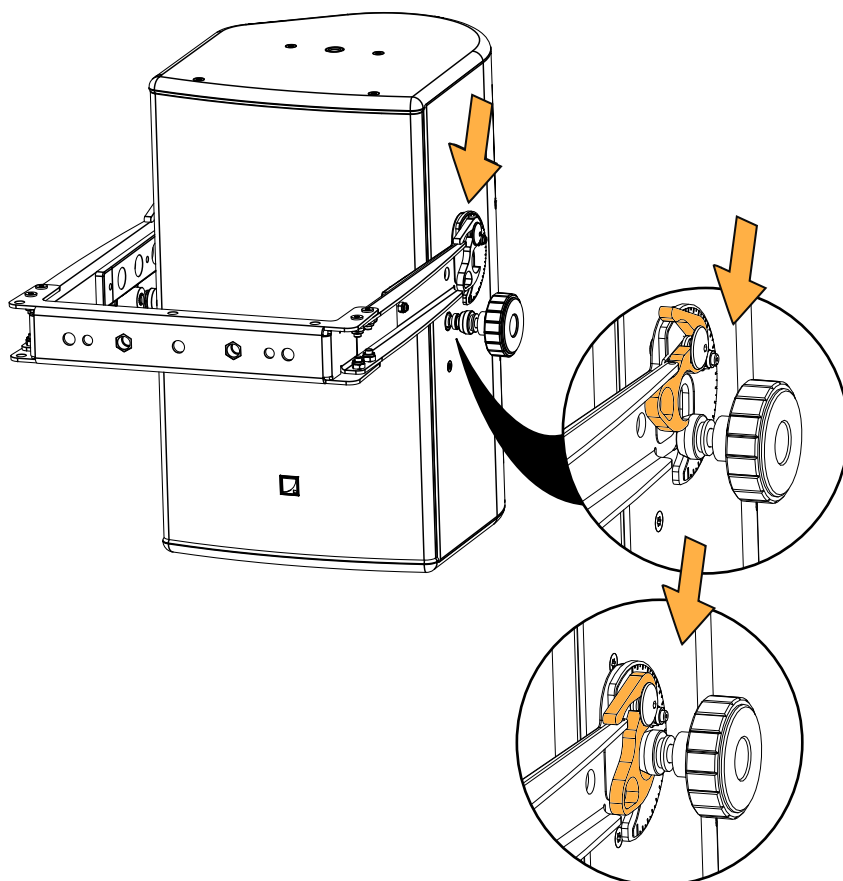

Alternatively, use the additional hole on the U-bracket.



The hooks on the bracket must be oriented towards the front of the enclosure.

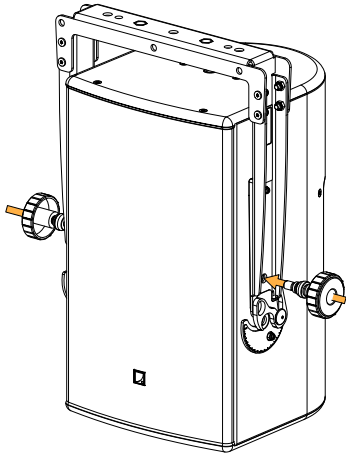

Make sure the safety washer goes through the hole on the bracket.

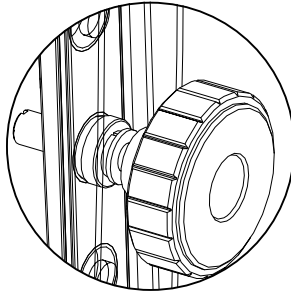
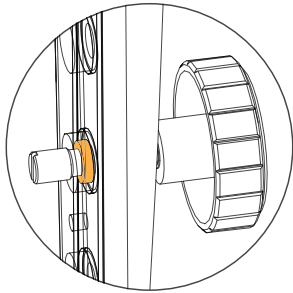

4. Tighten the knobs and fly the enclosure with a clamp.

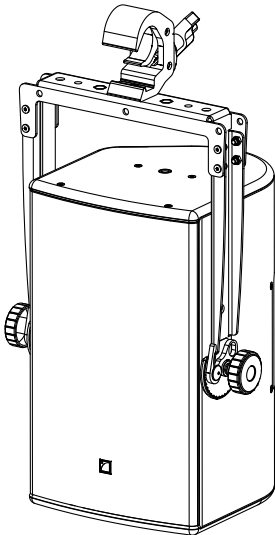

5. Loosen the knobs to set the site angle.

Use the screw as a reference point to read the label.

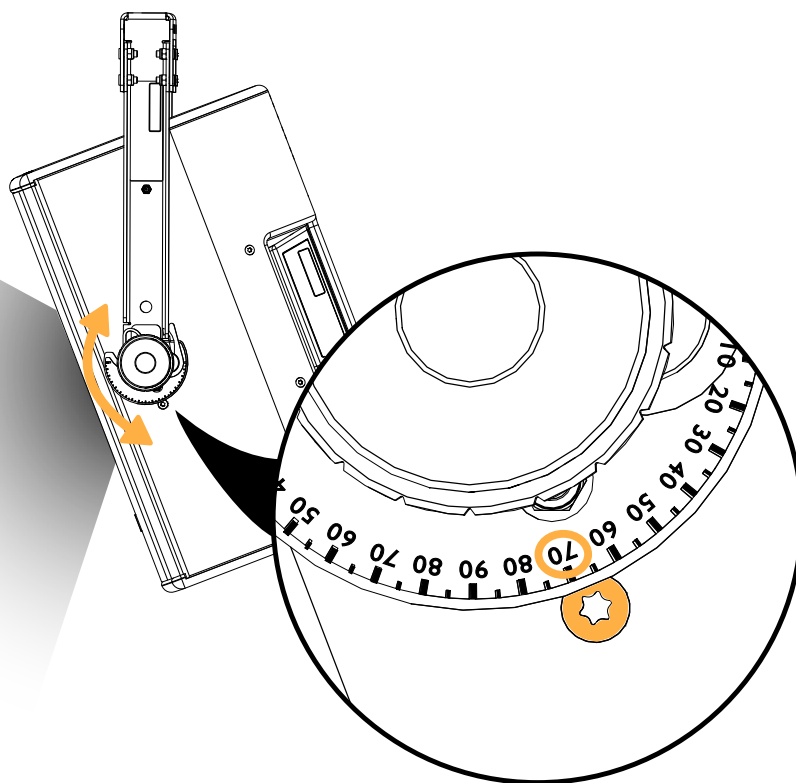

6. Tighten the knobs.

Make sure the enclosure is steady.

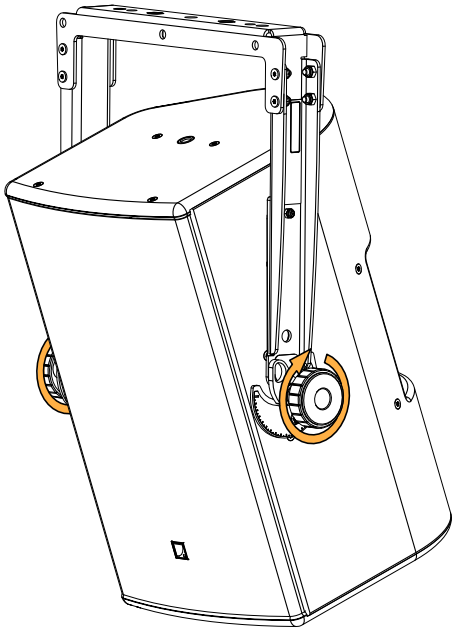

When using the additional hole on the U-bracket, consider the maximum negative site angle available.

Maximum angles

-28°

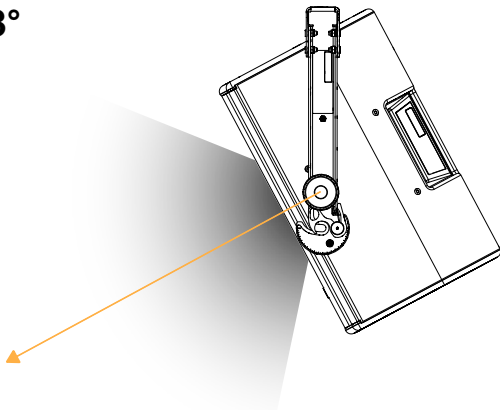

Disassembly

Procedure

1. Place the enclosure on a flat surface.
2. Loosen the knobs.
3. Pull on the safety mechanism and remove the U-bracket from the enclosure.

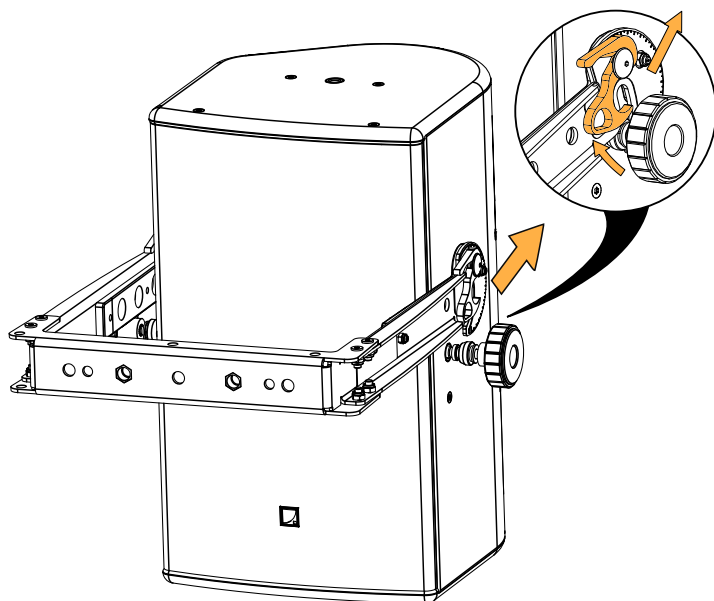

Flying with X-UL8i

type of deployment	flying
rigging accessories	X-UL8i
	2 × M10 screws and washers (provided)
additional material	M10 (3/8") truss clamp
tools	electric screwdriver with torque selector
	T50 Torx bit
min number of operators	1

Additional safety for flown arrays

When flying an enclosure, use the M8 DIN580 threaded insert to implement a secondary safety.

Assembly

Procedure

1. Drive the screws in the inserts on the enclosure.
Stop when the threading is halfway in.

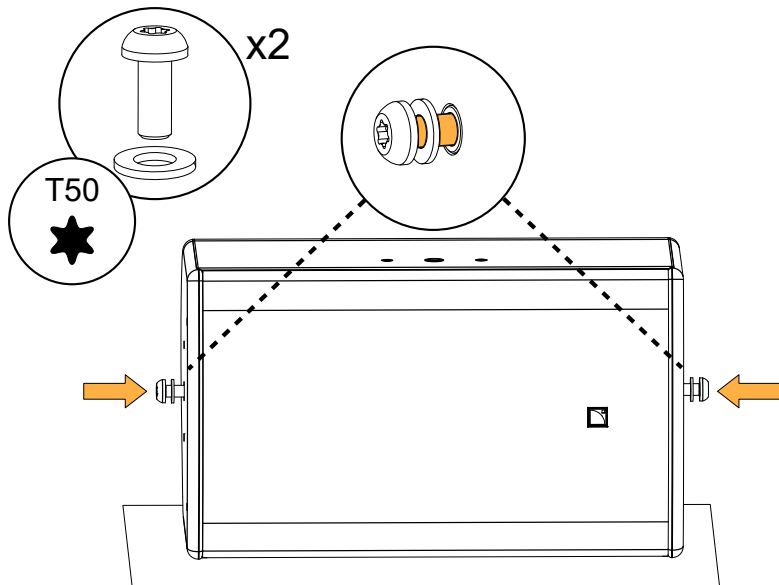

2. Place the U-bracket around the assembly.
Place the washers between the screw heads and the hooks.

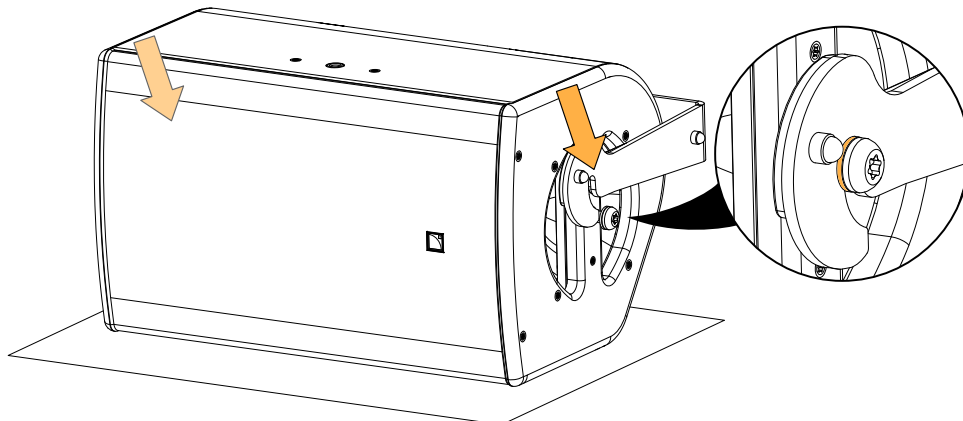

3. Tighten the screws and fly the enclosure with a truss clamp.

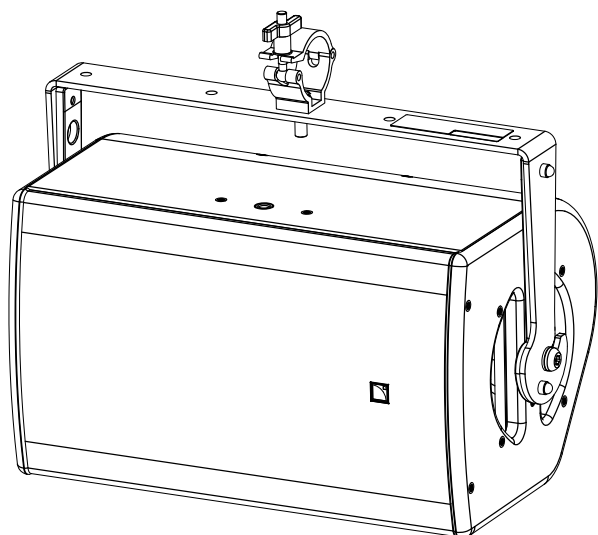

4. Loosen the screws to set the site angle.
Use an inclinometer or a digital level if necessary.

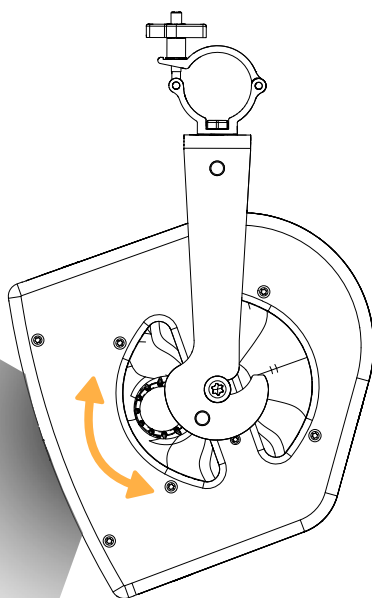

5. Tighten the screws.
Apply a 7 N.m. torque. Make sure the enclosure is steady.

Flying with X-BAR

type of deployment	flying
rigging accessories	X-BAR
	Ø12 mm shackles WLL 1 t (provided)
	CLAMP250 (optional)
min number of operators	1

Additional safety for flown arrays

When flying an enclosure, use the M8 DIN580 threaded insert to implement a secondary safety.

Site angles with X-BAR

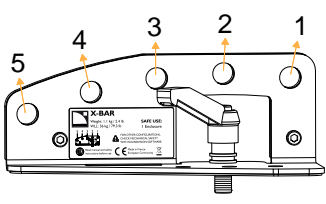
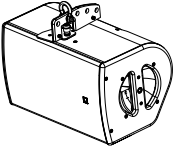
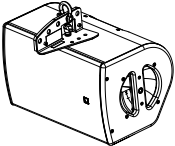
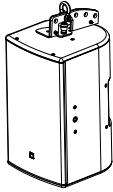
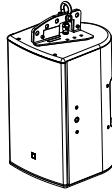
X-BAR hole N°	site angle			
	horizontal		vertical	
	rear extension	front extension	rear extension	front extension
				
1	28°	1°	5°	-15°
2	16°	14°	-5°	-6°
3	3°	27°	-14°	3°
4	-11°	37°	-23°	13°
5	-24°	47°	-31°	22°

Assembly

Procedure

1. Lay the enclosure on a flat surface.

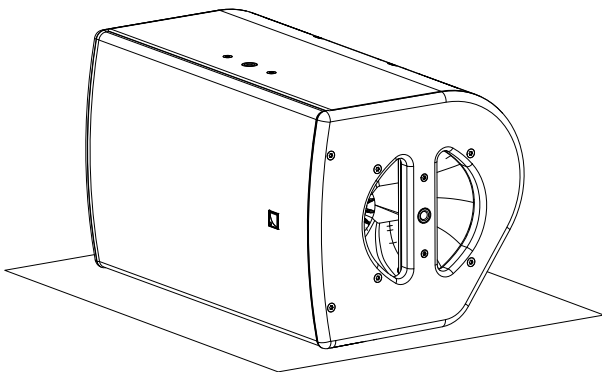

2. Drive the X-BAR in the insert.

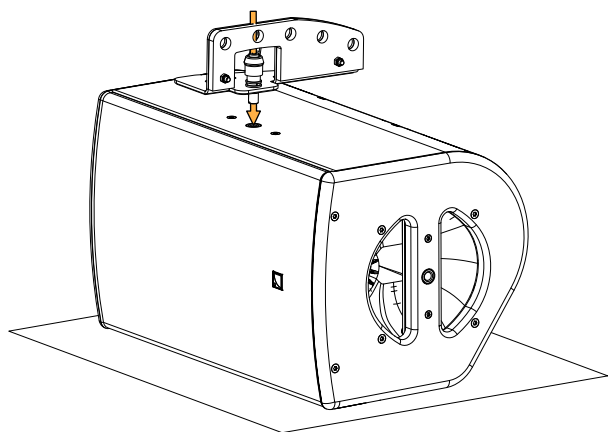

3. Rotate the X-BAR until perpendicular to the front grill.
Use the screws as reference points.

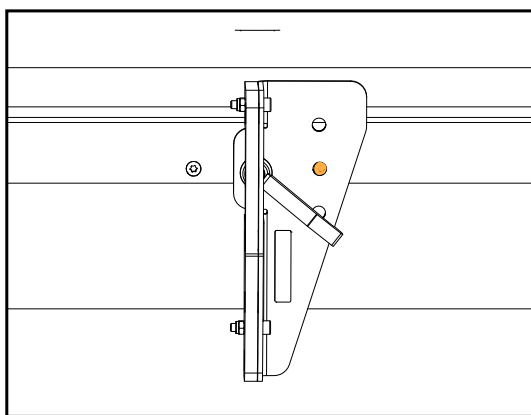
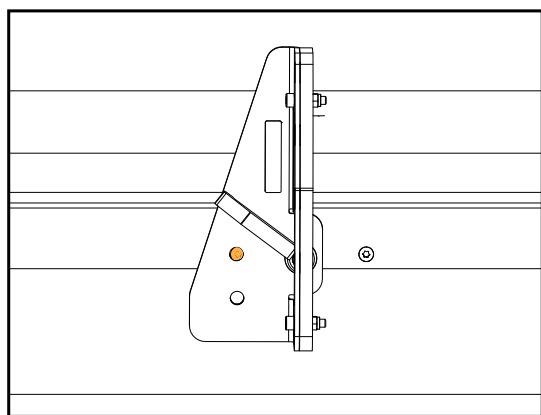

4. Tighten the X-BAR.

a) Lift the lever and rotate it counter-clockwise, release the lever and rotate it clockwise.

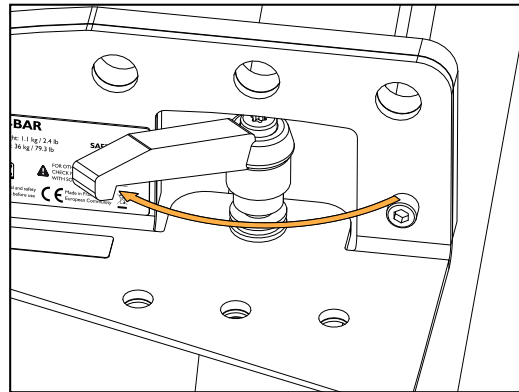
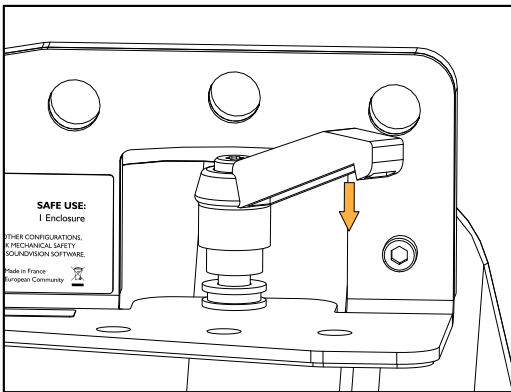
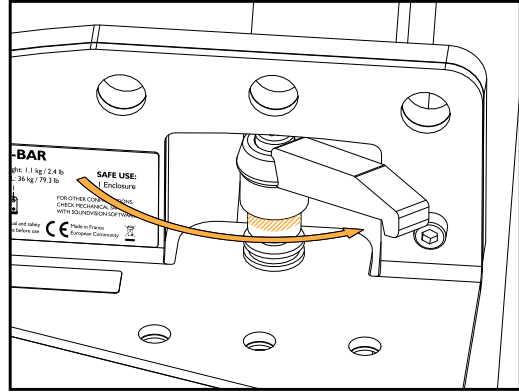
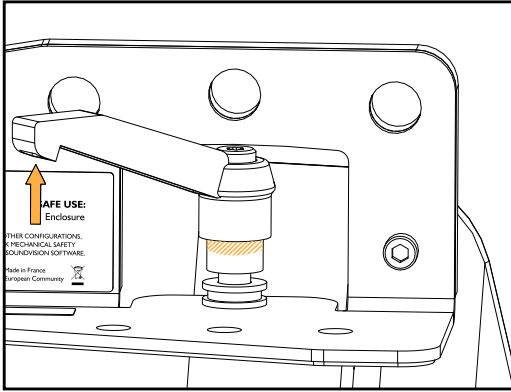

Repeat until the X-BAR is tightly secured.

b) Finally, store the lever on the right.

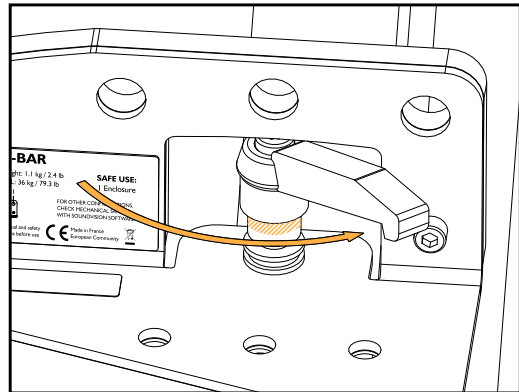
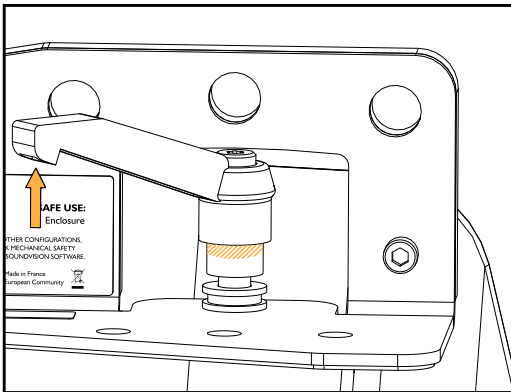

5. Position the shackle or CLAMP250 to select the site angle.

Refer to [Site angles with X-BAR](#) (p.58).

6. Lift the assembly.

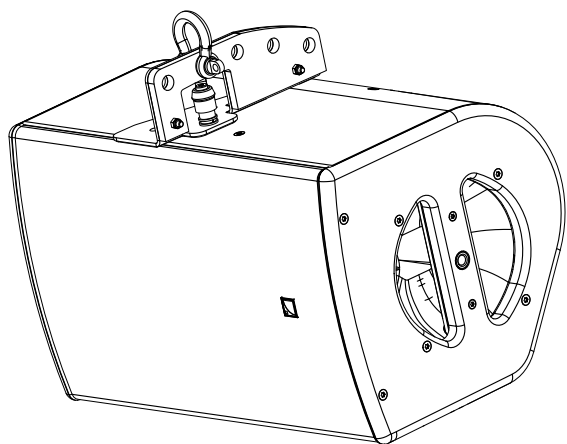

Disassembly

Procedure

1. Take down the assembly.
2. Lift the lever and rotate it clockwise.

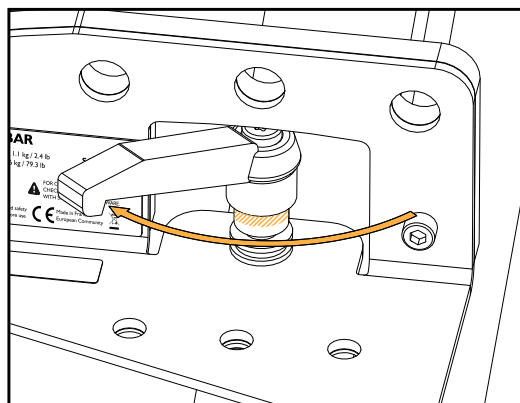
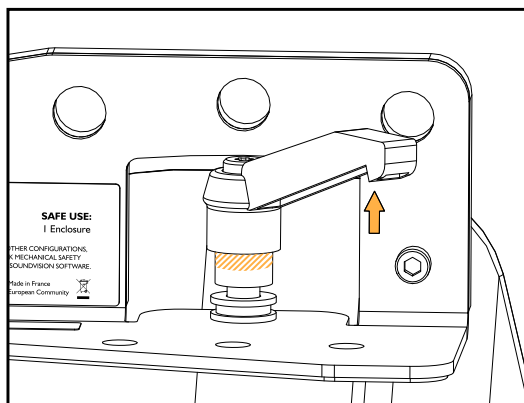

3. Release the lever and rotate it counter-clockwise.

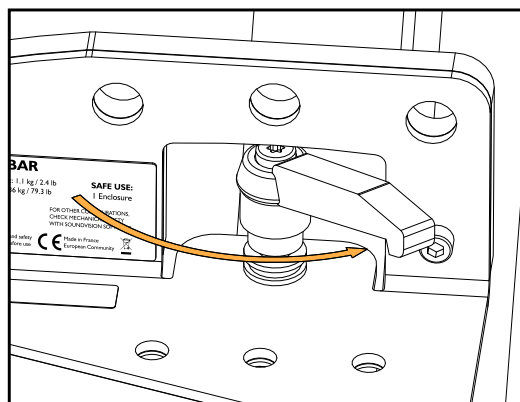
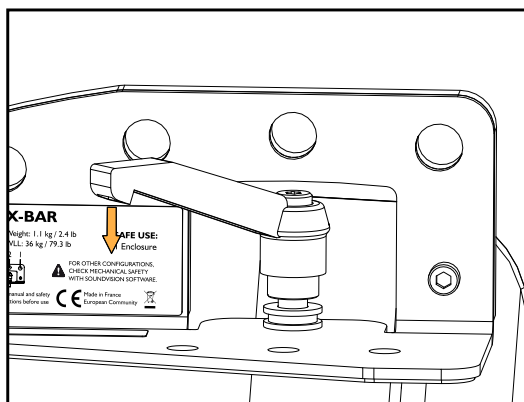

4. Repeat until the X-BAR can be removed.

Pole-mounting

Pole-mounting with X-US8

type of deployment	pole-mounting
rigging accessories	X-US8
	EMBi
additional material	35 mm pole
tools	torque screwdriver
	T30 Torx bit
	T40 Torx bit
	10 mm wrench
	13 mm wrench
min number of operators	1

Risk of damaging the bracket safety mechanism

When using X-US8 and EMBi for pole-mounting X8, always use the additional holes on the bracket.
Do not use X-UL8 with EMBi.

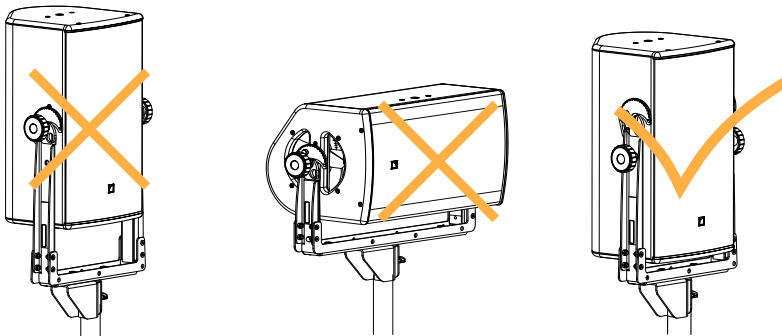

Do not use EMBi with X-UL8i.

In pole-mounting position, the screws are not maintained by the bracket hooks.

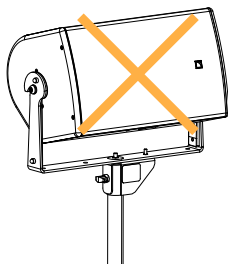

Assembly

Procedure

1. Secure EMBi to the U-bracket with the provided bolts and nuts.

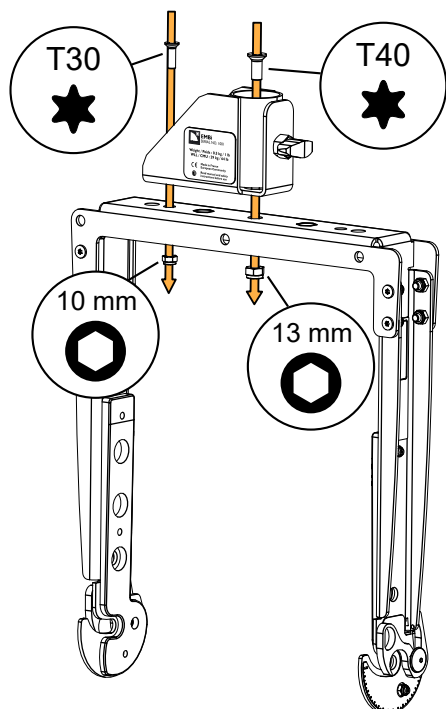

2. Secure the U-bracket to the enclosure using the additional holes.



The hooks on the bracket must be oriented towards the front of the enclosure.

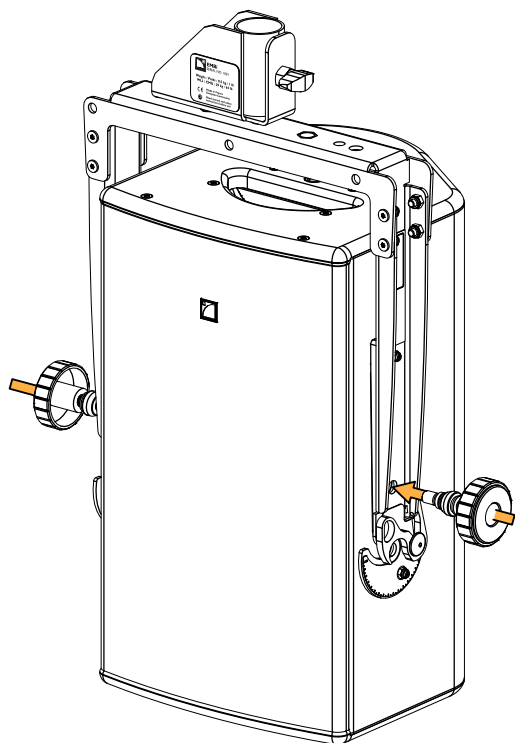



Make sure the safety washer goes through the hole on the bracket.

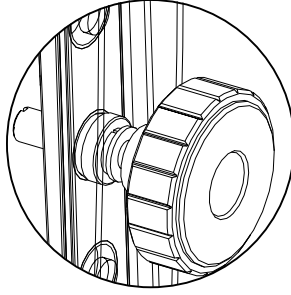
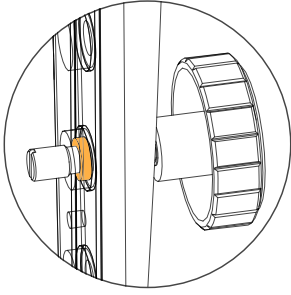

3. Tighten the knobs, reverse the assembly and mount it on a pole.

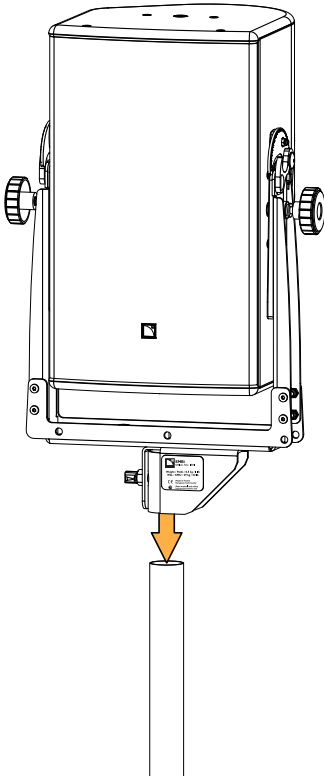

4. Tighten EMBi.

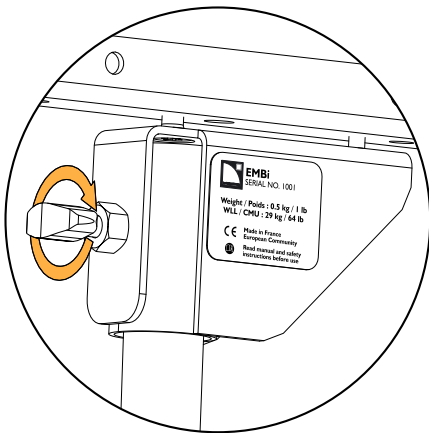

5. Loosen the knobs to set the site angle.

i Consider the maximum positive site angle available.

Maximum angles

+28°

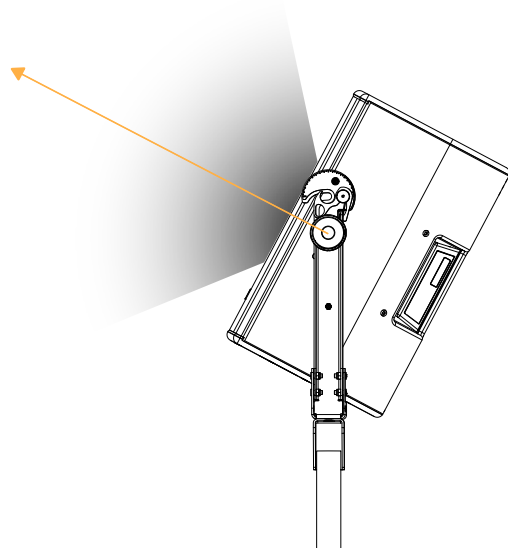

6. Tighten the knobs.

Make sure the enclosure is steady.

The assembly can be mounted on a tripod or on a subwoofer.

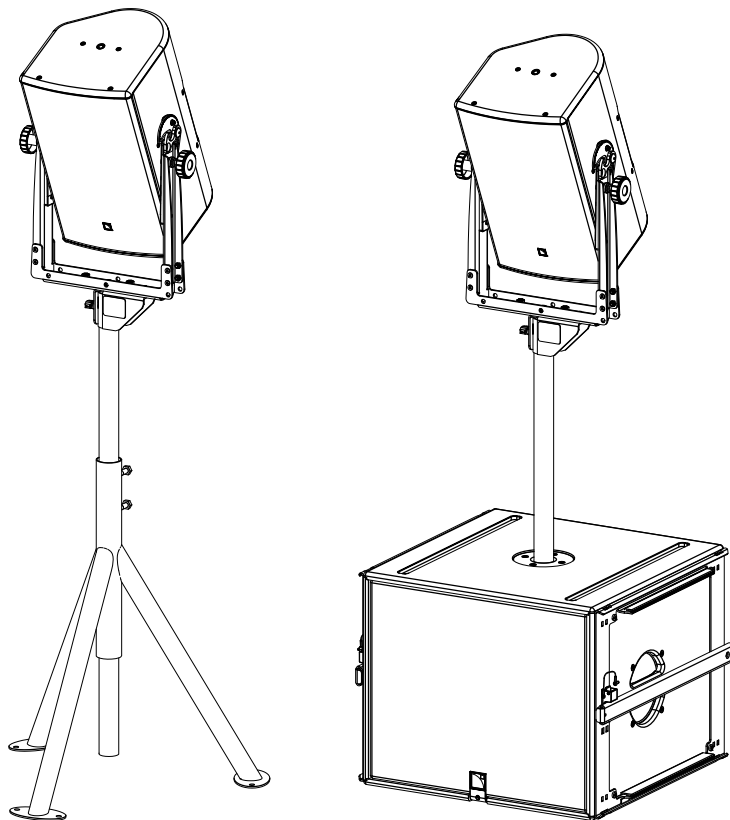

Disassembly

About this task



Remove the assembly from the pole before disassembling the enclosure and the bracket.

Procedure

1. Loosen EMBi to remove the assembly from the pole.

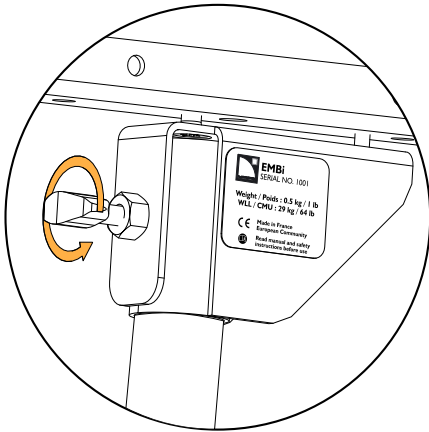

2. Remove the bracket from the enclosure.

Connection to LA amplified controllers

! Refer to the **Amplification reference** technical bulletin for the latest information on compatibility with amplified controllers and cabling schemes for all enclosure types.

Enclosure drive capacity per amplified controller

Make sure the total number of connected enclosures does not exceed the maximum number of enclosures per controller (refer to the footnotes).

	LA4X	LA8	LA12X
	per output [*] / total	per output [*] / total	per output [*] / total
X8	2 / 8	3 / 8	3 / 12

Cabling schemes for X8

Refer to the cabling schemes to connect the enclosures to different types of output configurations.

One-channel speakON output

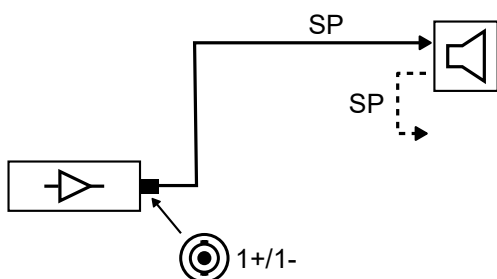

Two-channel speakON output

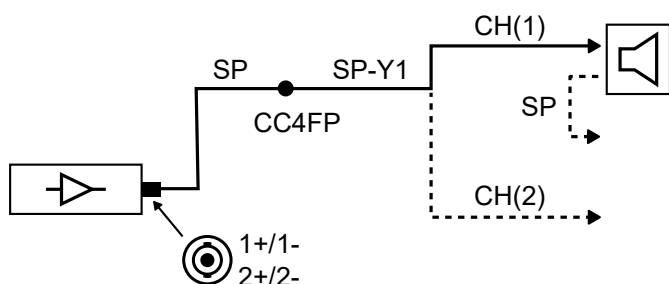

Four-channel CA-COM output

* For passive loudspeakers, the value corresponds to the number of enclosures in parallel on the output. For active loudspeakers, the value corresponds to the number of sections in parallel on the output.

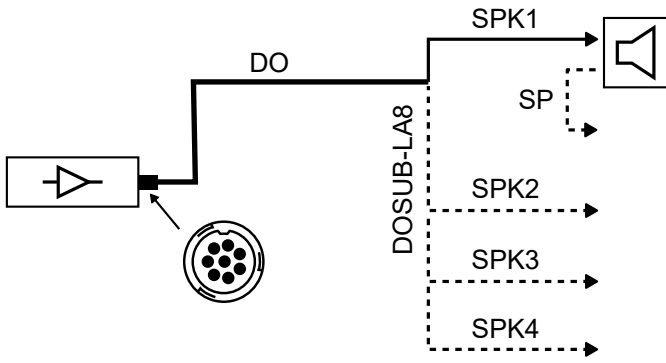

Corrective maintenance

Introduction

This section contains the following maintenance procedures:

X8

- [D/R - Grill](#) (p.71)
- [D/R - Coaxial loudspeaker](#) (p.72)
- [D/R - Diaphragm](#) (p.73)

For advanced maintenance, contact your L-Acoustics representative.

Tools and consumables

Before performing maintenance on this product, make sure all the tools listed are available. References are given for FACOM® products in this table. Other manufacturers can be used.

name	reference	distributor
set of 6-point 1/4" sockets*	RL.NANO1 / R.360NANO	FACOM
torque screwdriver (2 - 10 N.m)*	A.404	FACOM
3 mm hex wrench	-	-
compressed air blower	-	-
double face adhesive tape	-	-



* included in the L-Acoustics Maintenance Toolcase.

Maintenance Toolcase

The Maintenance Toolcase is a carry-on suitcase that includes all the tools required to perform maintenance on L-Acoustics products. This toolcase is aimed at Certified Providers.

The Maintenance Toolcase uses a Peli™ 1510 Protector case that features three pre-cut layers of foam to safely fit the tools. The Maintenance Toolcase includes tools manufactured by FACOM®, Fluke®, Tohnichi, ABUS, and Würth.



All third-party trademarks, registered trademarks, or product names are the property of their respective owners.

X8

Disassembly and Reassembly procedures

In order to operate, follow the order outlined here. Each assembly refers to the corresponding Disassembly/ Reassembly (D/R) procedure and the necessary repair kit (KR).

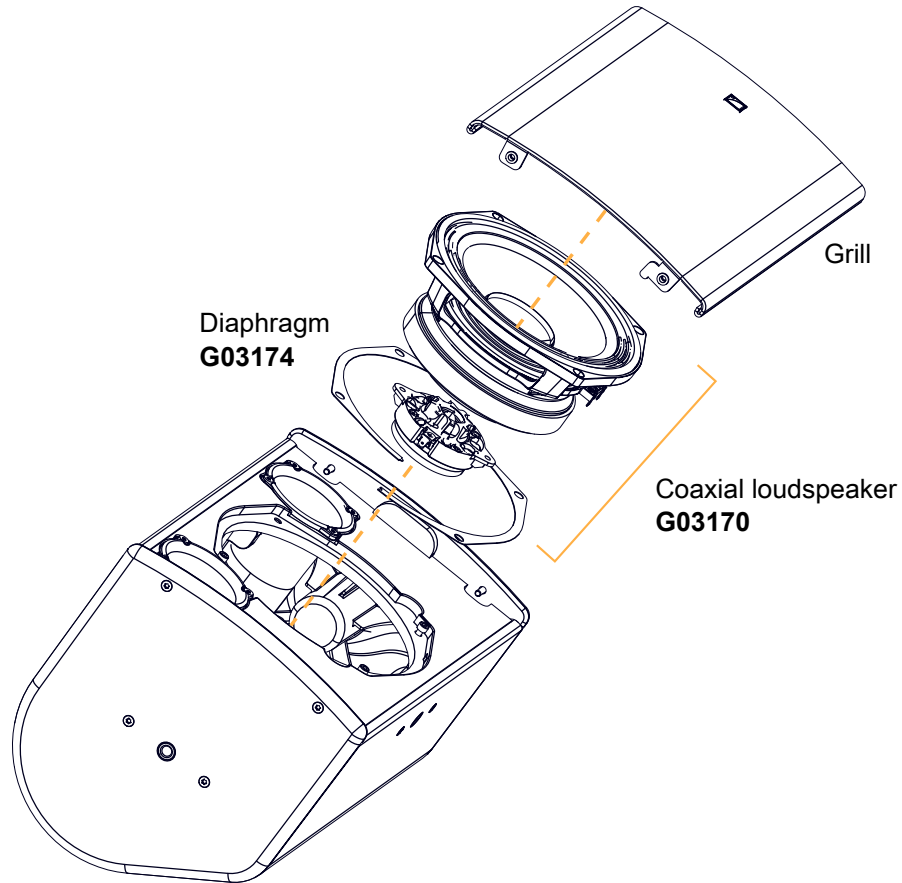

D/R - Grill

Tools

- torque screwdriver
- T25 Torx bit

Repair kit

G03170 - KR coaxial speaker X8 or

G03174 - KR diaphragm X8

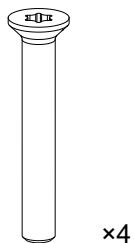

S100062

M5×35 Torx

Exploded view

! For safety reasons, always use the new screws and spare parts provided in the KR.
If no new screws are available, use blue threadlocker.

! Gradually tighten the screws following a star pattern.

Position the logo on the right side.

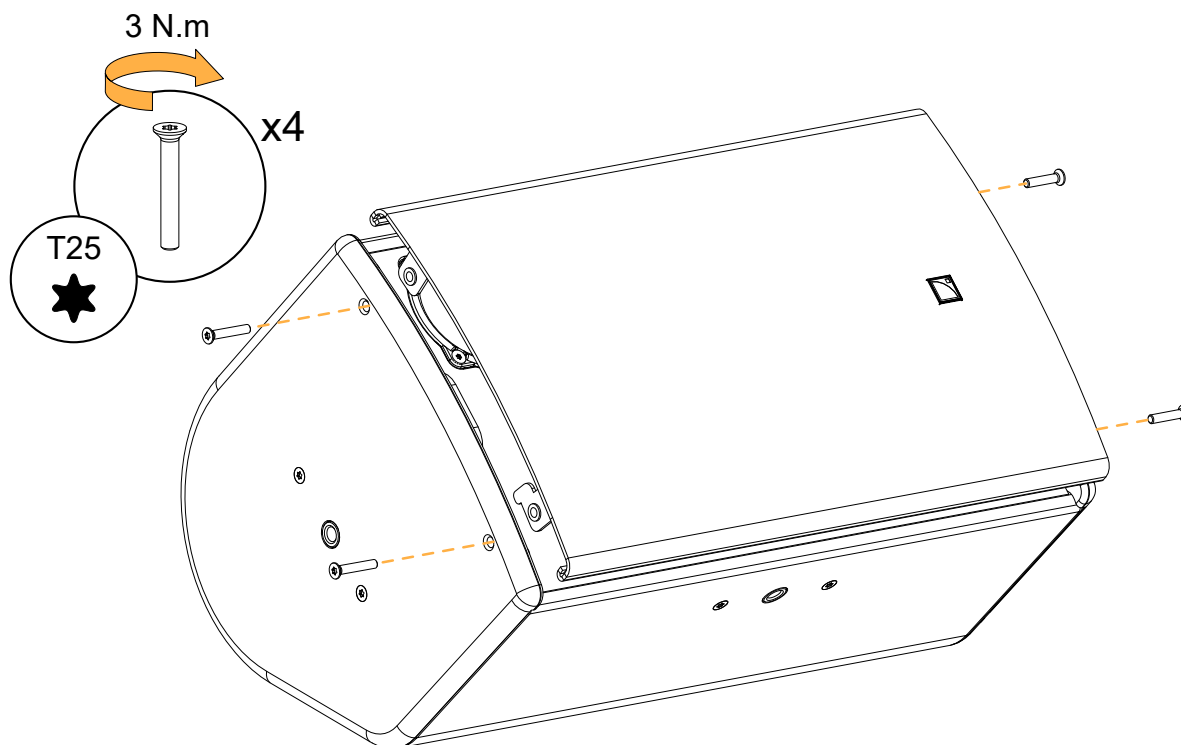

D/R - Coaxial loudspeaker

Tools

- torque screwdriver
- 4 mm hex bit

Repair kit

G03170*

KR coaxial speaker X8

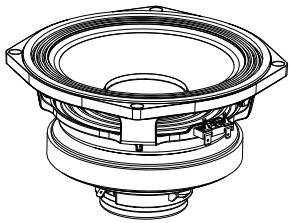

x1

18466_2

8" coaxial speaker - 8 ohms

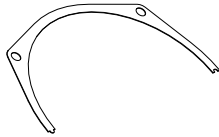

x2

100604

8" speaker gasket



x4

S342

M5x20 hex

* The screws and gaskets are also available in G03174 - KR diaphragm X8.

Prerequisite

Grill disassembled.

See [D/R - Grill](#) (p.71).

Exploded view



For safety reasons, always use the new screws and spare parts provided in the KR.
If no new screws are available, use blue threadlocker.



Gradually tighten the screws following a star pattern.



If the speaker gasket is damaged, remove and replace it.

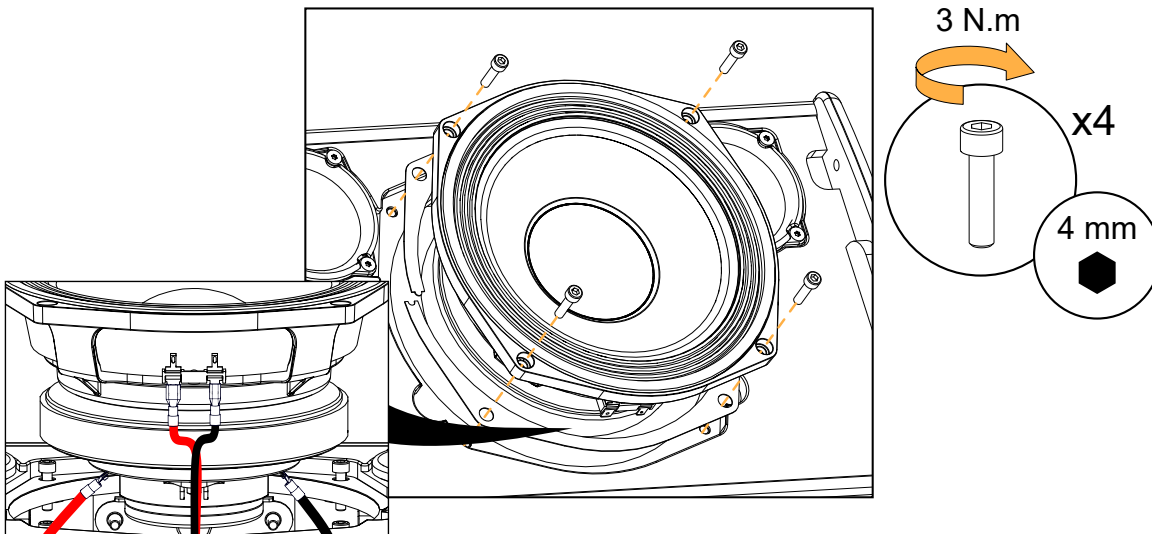

What to do next

Perform the [Acoustical check](#) (p.33) procedures.

D/R - Diaphragm

Tools

- torque screwdriver
- 3 mm hex bit
- 3 mm hex wrench
- compressed air blower

Consumables

- double face adhesive tape

Repair kit

G03174

KR diaphragm X8

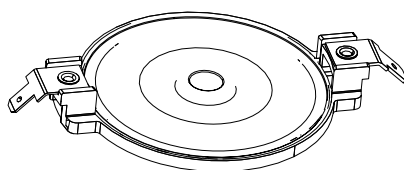

×1

17704

X8 diaphragm assembly



×4

S182

M4×12 hex

Prerequisite

Grill disassembled.

Coaxial speaker removed.

The speaker is placed on a flat surface in a dust-free environment.

See [D/R - Grill](#) (p.71).

See [D/R - Coaxial loudspeaker](#) (p.72).

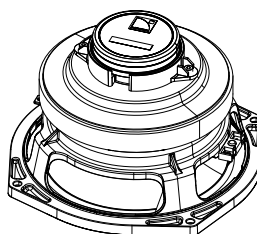

Disassembly

Procedure

1. Remove the two screws securing the HF driver.
Use the 3 mm hex bit.
2. Remove the HF driver and remove the gasket between the HF and LF driver.
3. Place the HF driver on a flat surface.
4. Remove the four screws securing the cover and remove the cover.
Use the 3 mm hex bit.
5. Pierce the label and carefully remove the center screw while holding the cone in place.
Use the 3 mm hex bit.



Discard the paper disk to avoid parasitic vibrations.

6. Remove the cone.
7. Carefully remove the diaphragm holding it by the connectors.
8. If there are black spacers on the air gap, do not remove them.

Reassembly

About this task



For safety reasons, always use the new screws and spare parts provided in the KR.

Procedure

1. Clean the driver and the air gap.

Use a blower or double face adhesive tape to clean any particle.



Make sure the air gap is perfectly clean before moving to the next step.

2. Carefully place the diaphragm.

If there are black spacers, make sure they remain in place.

3. Position the diaphragm using the screw holes as reference points.

The connectors must be positioned halfway between two screw holes.

4. Place the cone in the middle.

5. While holding the cone in place, drive the center screw manually using the 3 mm hex wrench.

6. Secure the cover with four S182 screws.

- a) Gradually secure each screw manually with the 3 mm hex wrench.

Follow a star pattern.

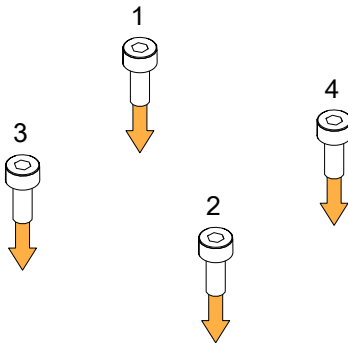

- b) Tighten the screws in the same order with the torque screwdriver.

Use the 3 mm hex bit. Set the torque to 1.7 N.m.

7. While holding the cone in place, tighten the center screw with the torque screwdriver.

Use the 3 mm hex bit. Set the torque to 1.7 N.m.

8. Place the gasket on the LF driver.

9. Carefully position the HF driver on the LF driver.

Use the connectors as reference points. When facing the LF driver connectors, the small HF driver connector must be on the left, and the larger one on the right.

10. Secure the HF driver on the LF driver with the two screws.

Use the 3 mm hex bit. Set the torque to 3 N.m.

What to do next

Perform the [Acoustical check](#) (p.33) procedures.

Specifications

X8 specifications

Description	2-way passive coaxial enclosure: 8" LF + 1.5" HF diaphragm, amplified by LA4X / LA8 / LA12X
Usable bandwidth (-10 dB)	60 Hz - 20 kHz ([X8])
Maximum SPL ¹	129 dB ([X8])
Nominal directivity (-6 dB)	axisymmetric 100°
Monitoring angle	35°
Transducers	LF: 1 × 8" cone driver HF: 1 × 1.5" diaphragm compression driver, neodymium
Acoustical load	bass-reflex, L-Vents, conical waveguide
Nominal impedance	8 Ω
Connectors	IN: 1 × 4-point speakON LINK: 1 × 4-point speakON
Rigging and handling	1 handle DIN580-compatible M8 threaded insert 4 M10 threaded inserts 1 × 35 mm pole socket
Weight (net)	12 kg / 26.5 lb
Cabinet	premium grade Baltic beech and birch plywood
Front	coated steel grill acoustically neutral 3D fabric
Finish	dark grey brown Pantone 426 C pure white RAL 9010 custom RAL code on special order
IP	IP43

¹ Peak level measured at 1 m under free field conditions using pink noise with crest factor 4 (preset specified in brackets).

X8 dimensions

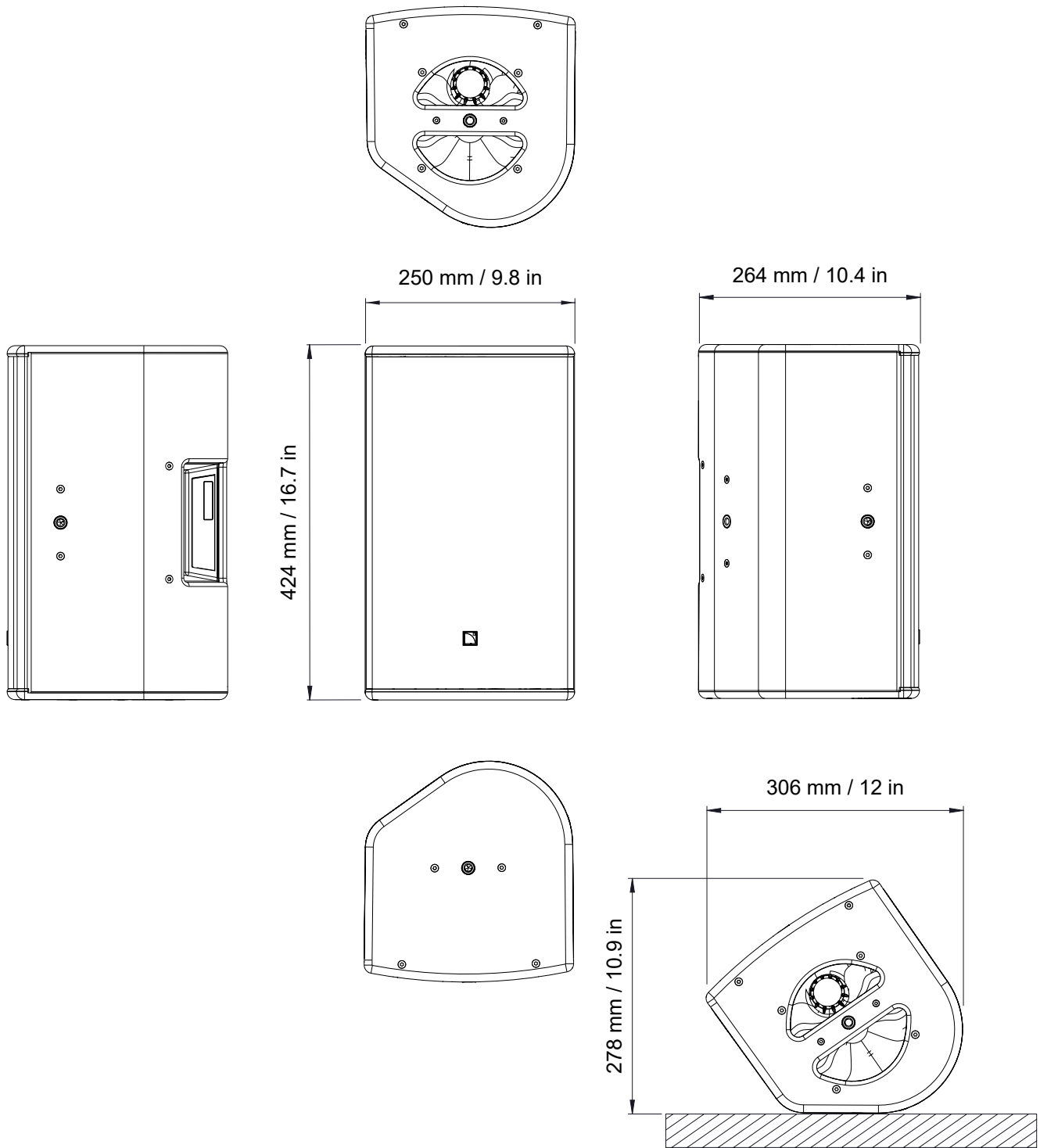

SB15m specifications

Description	High power compact subwoofer : 1 × 15", amplified by LA2Xi / LA4X / LA8 / LA12X
Low frequency limit	40 Hz ([SB15_100])
Maximum SPL¹	137 dB ([SB15_100]) with LA2Xi (bridge mode) / LA4X / LA8 / LA12X 131 dB ([SB15_100]) with LA2Xi
Directivity	standard or cardioid
Transducers	1 x 15" cone driver
Acoustical load	bass-reflex, L-Vents
Nominal impedance	8 Ω
Connectors	IN: 1 × 4-point speakON LINK: 1 × 4-point speakON
Rigging and handling	2 handles 2 coupling bars and 2 locking tabs 1 × 35 mm pole socket
Weight (net)	36 kg / 79.4 lb
Cabinet	premium grade Baltic birch plywood
Front	coated steel grill acoustically neutral 3D fabric
Rigging components	high grade steel with anti-corrosion coating
Finish	dark grey brown Pantone 426 C pure white RAL 9010 custom RAL code on special order
IP	IP55

¹ Peak level at 1 m under half space conditions using pink noise with crest factor 4 (preset specified in brackets).

SB15m dimensions

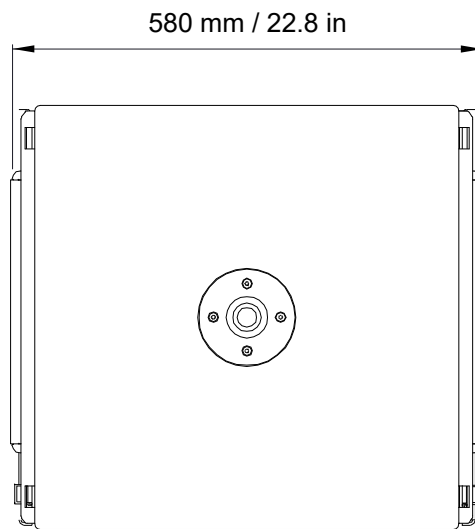
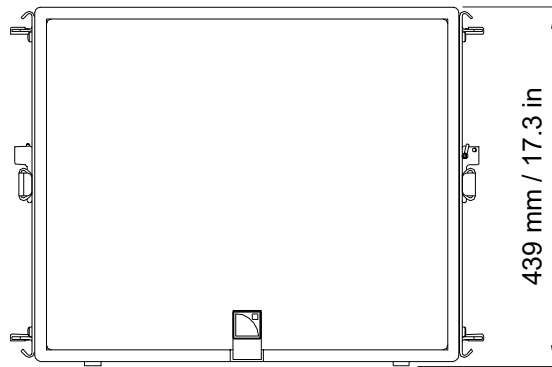
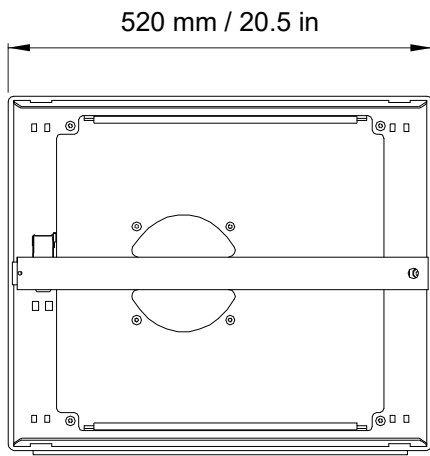

X-UL8 specifications

Description	Long U-bracket for X8
Weight (net)	2.3 kg / 5 lb
Material	high grade steel with anti-corrosion coating

X-UL8 dimensions

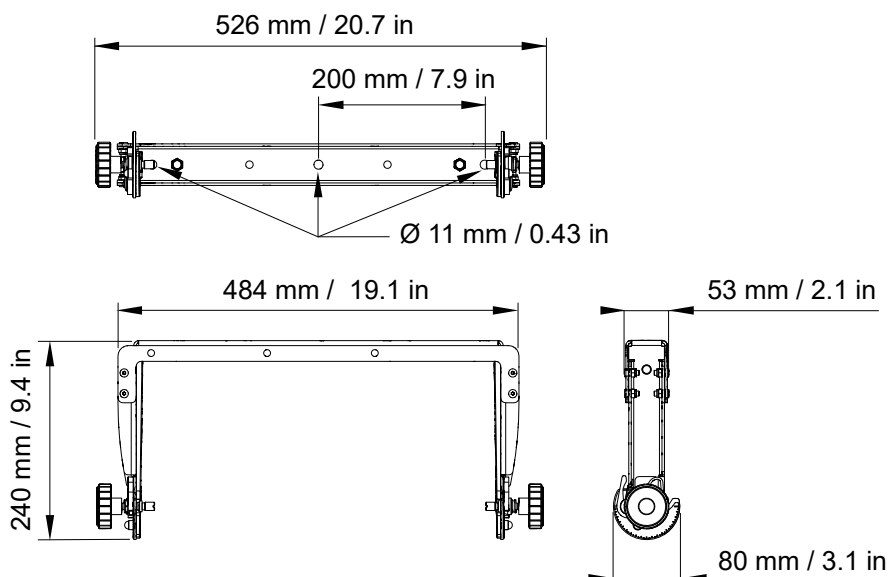

X-UL8i specifications

Description	Long U-bracket for X8 (installation version)
Weight (net)	2 kg / 4.4 lb
Material	high grade steel with anti-corrosion coating

X-UL8i dimensions

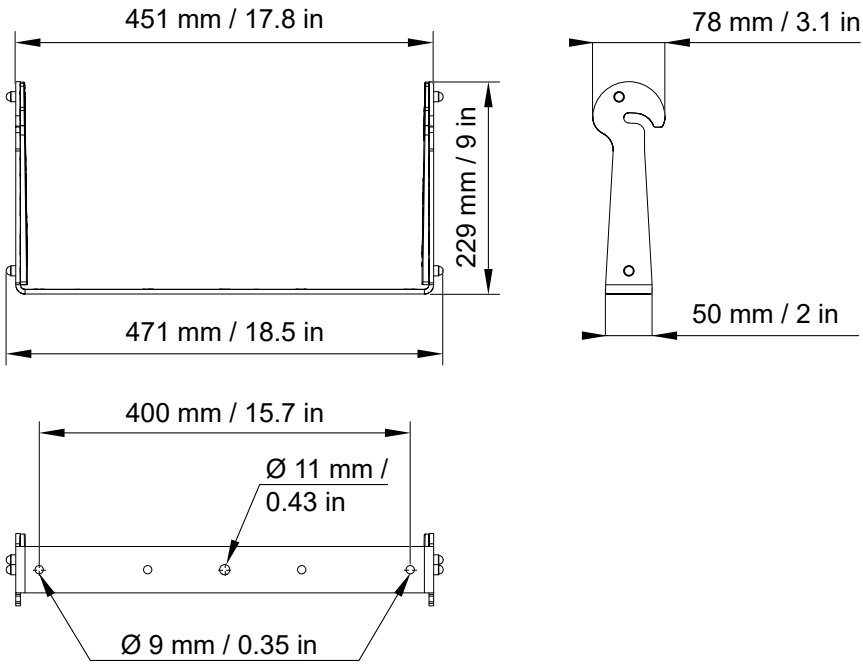

X-US8 specifications

Description	Short U-bracket for X8
Weight (net)	2.3 kg / 5 lb
Material	high grade steel with anti-corrosion coating

X-US8 dimensions

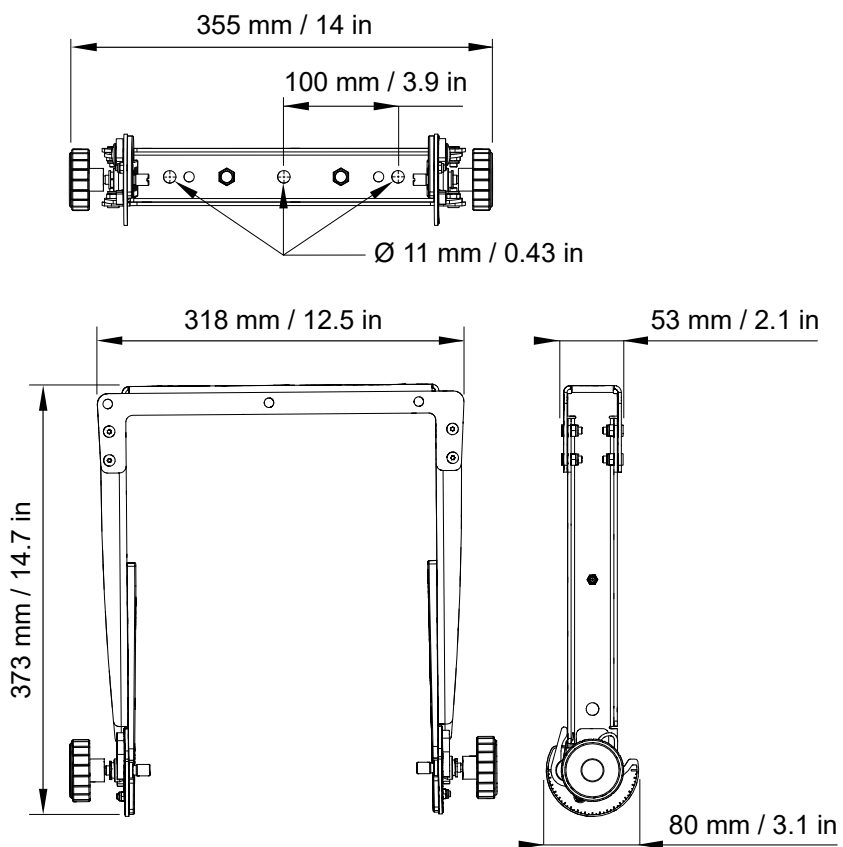

X-BAR specifications

Description	Rigging bar for 1 enclosure 1 × Ø12 mm shackle WLL 1 t
Weight (net)	1.1 kg / 2.4 lb
Material	high grade steel with anti-corrosion coating

X-BAR dimensions

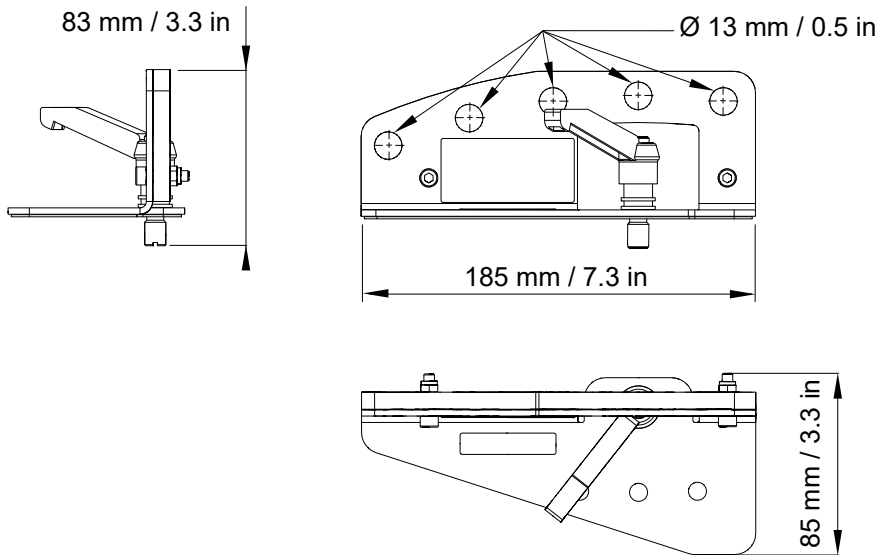

X-UTILT specifications

Description	U-bracket wallmount for X series with tilt adjustment
Weight (net)	1.5 kg / 3.3 lb
Material	high grade steel with anti-corrosion coating

X-UTILT dimensions

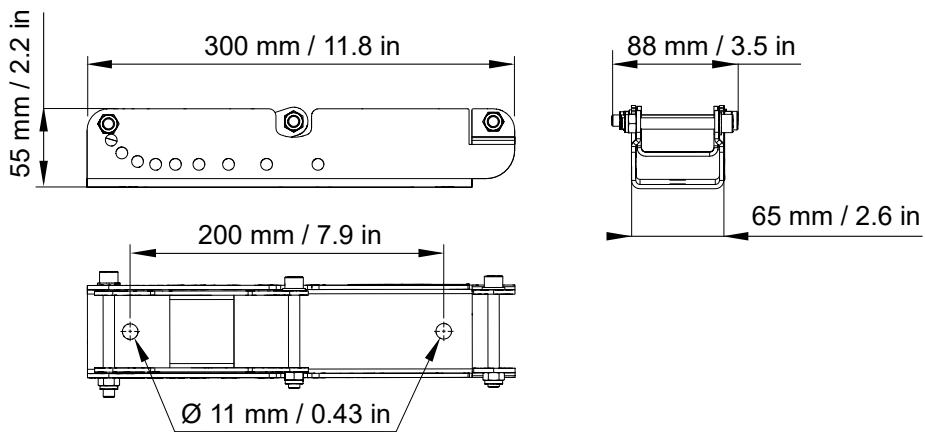

EMBi specifications

Description	Pole mount socket: 8XTi/12XTi and X series
Weight (net)	0.5 kg / 1 lb
Material	high grade steel with anti-corrosion coating

EMBi dimensions

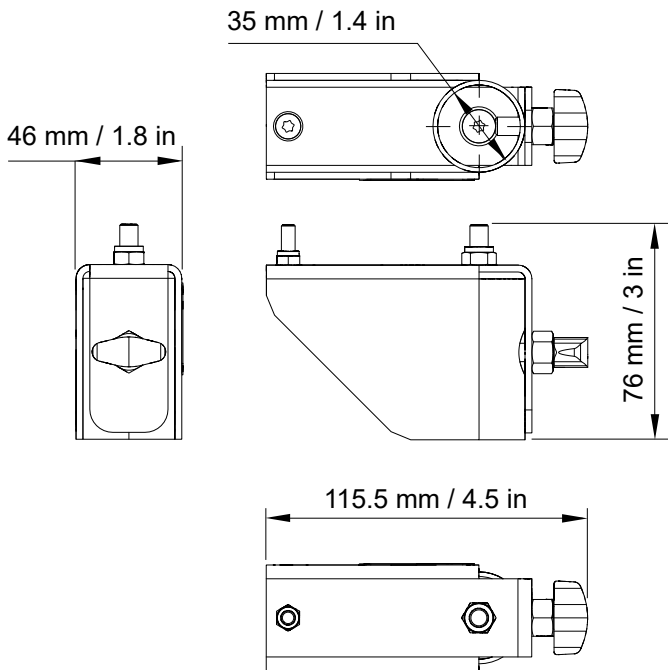

Recommendation for speaker cables



Cable quality and resistance

Only use high-quality fully insulated loudspeaker cables made of stranded copper wire.

Use cables with a gauge offering low resistance per unit length and keep the cables as short as possible.

It is good practice to keep loudspeaker cables short to ensure optimal system performance. L-Acoustics strongly recommends using cables of similar type, length, and gauge to address symmetrical deployment of loudspeakers, such as stereo systems, L-ISA frontal systems, or outfill systems.



For more information about cable effect on loudspeaker frequency response, refer to the publication **Demystifying the effects of loudspeaker cables** on the L-Acoustics website, in **Education > Scientific resources > Scientific publications**.

Refer to the following table for recommended cable length for uncompromised performance.

cable gauge			recommended maximum length					
			8 Ω load		4 Ω load		2.7 Ω load	
mm ²	SWG	AWG	m	ft	m	ft	m	ft
1.5	18	16	18	60	9	30	–	–
2.5	15	14	30	100	15	50	10	33
4	13	11	50	160	25	80	17	53
6	11	9	74	240	37	120	25	80

Use the more detailed L-Acoustics calculation tool to evaluate cable length and gauge based on the type and number of loudspeakers connected. The calculation tool is available on our website:

<https://www.l-acoustics.com/installation-tools/>



L-ACOUSTICS

L-Acoustics

13 rue Levacher Cintrat - 91460 Marcoussis - France

+33 1 69 63 69 63 - info@l-acoustics.com

www.l-acoustics.com

 **L-ACOUSTICS**
GROUP